



FLECK SXT TIMER
SERVICE MANUAL



TABLE OF CONTENTS

TABLE OF CONTENTS.....	2
JOB SPECIFICATION SHEET.....	2
TIMER FEATURES.....	3
TIMER OPERATION.....	4
MASTER PROGRAMMING MODE CHART.....	5
MASTER PROGRAMMING MODE.....	6
MASTER PROGRAMMING MODE <i>continued</i>	7
MASTER PROGRAMMING MODE <i>continued</i>	8
USER PROGRAMMING MODE.....	9
DIAGNOSTIC PROGRAMMING MODE.....	10
2510/2750/2850S TIMER ASSEMBLY.....	11
9000/9100/9500 TWIN TANK TIMER ASSEMBLY.....	12
3/4-INCH PLASTIC TURBINE METER ASSEMBLY.....	13
PLASTIC PADDLE METER ASSEMBLY.....	14
3/4-INCH BRASS PADDLE METER ASSEMBLY.....	15
1-INCH BRASS PADDLE METER ASSEMBLY.....	16
1-INCH STAINLESS STEEL METER ASSEMBLY.....	17
INLINE PLASTIC TURBINE METER ASSEMBLY.....	18
1-1/2 INCH BRASS METER ASSEMBLY.....	19
1-1/2 INCH STAINLESS STEEL METER ASSEMBLY.....	20
3/4-INCH, 1-INCH or 1-1/2 INCH PADDLE WHEEL METER CAP ASSEMBLY.....	21
TROUBLESHOOTING.....	22
2510SXT WIRING DIAGRAM.....	23
2750SXT/2850SXT WIRING DIAGRAM.....	24
9000SXT/9100SXT/9500SXT WIRING DIAGRAM.....	25
SERVICE ASSEMBLIES.....	26

JOB SPECIFICATION SHEET

Job Number: _____
Model Number: _____
Water Hardness: _____ ppm or gpg
Capacity Per Unit: _____
Mineral Tank Size: _____ Diameter: _____ Height: _____
Salt Setting per Regeneration: _____

1. Type of Timer:

- A. 7 Day or 12 Day
- B. Meter Initiated

2. Downflow: Upflow Upflow Variable

3. Meter Size:

- A. 3/4-inch Turbine
- B. 3/4-inch Paddlewheel
- C. 1-inch Turbine
- D. 1-inch Paddlewheel
- E. 1-1/2 inch Turbine
- F. 1-1/2 inch Paddlewheel
- G. Generic _____ Pulse Count _____ Model _____

4. System Type:

- A. System #4: 1 Tank, 1 Meter, Immediate, or Delayed Regeneration
- B. System #4: Time Clock
- C. System #4: Twin Tank

5. Timer Program Settings:

- A. Backwash: _____ Minutes
- B. Brine and Slow Rinse: _____ Minutes
- C. Rapid Rinse: _____ Minutes
- D. Brine Tank Refill: _____ Minutes
- E. Pause Time: _____ Minutes
- F. Second Backwash: _____ Minutes

6. Drain Line Flow Control: gpm

7. Brine Line Flow Controller: gpm

8. Injector Size#:

9. Piston Type:

- A. Hard Water Bypass
- B. No Hard Water Bypass

CALIFORNIA PROPOSITION 65 WARNING

▲ WARNING: This product contains chemicals known to the State of California to cause cancer or birth defects or other reproductive harm.

TIMER FEATURES

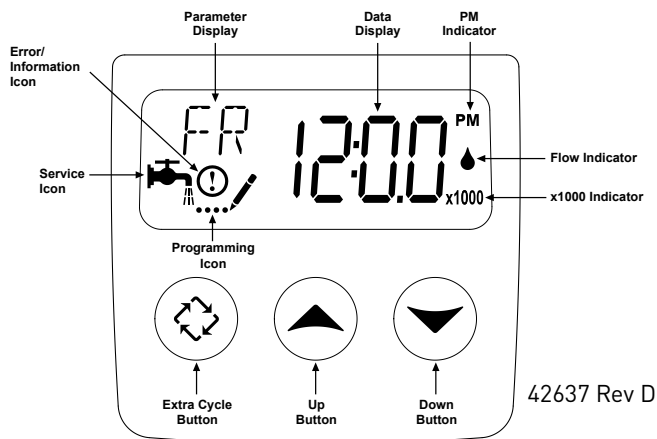

Figure 1

Features of the SXT:

- Power backup that continues to keep time and the passage of days for a minimum of 48 hours in the event of power failure. During a power outage, the control goes into a power-saving mode. It does not monitor water usage during a power failure, but it does store the volume remaining at the time of power failure.
- Settings for both valve (basic system) and control type (method used to trigger a regeneration).
- Day-of-the-Week controls.
- While in service, the display alternates between time of day, volume remaining or days to regeneration, and tank in service (twin tank systems only).
- The Flow Indicator flashes when outlet flow is detected.
- The Service Icon flashes if a regeneration cycle has been queued.
- A Regeneration can be triggered immediately by pressing the Extra Cycle button for five seconds.
- The Parameter Display displays the current Cycle Step (BW, BF, RR, etc) during regeneration, and the data display counts down the time remaining for that cycle step. While the valve is transferring to a new cycle step, the display will flash. The parameter display will identify the destination cycle step (BW, BF, RR, etc) and the data display will read "----". Once the valve reaches the cycle step, the display will stop flashing and the data display will change to the time remaining. During regeneration, the user can force the control to advance to the next cycle step immediately by pressing the extra cycle button.

Setting the Time of Day

1. Press and hold either the Up **or** Down buttons until the programming icon replaces the service icon and the parameter display reads TD.
2. Adjust the displayed time with the Up and Down buttons.
3. When the desired time is set, press the Extra Cycle button to resume normal operation. The unit will also return to normal operation after 5 seconds if no buttons are pressed.

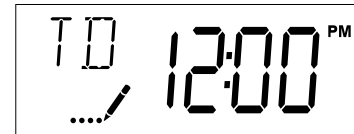

Queueing a Regeneration

1. Press the Extra Cycle button. The service icon will flash to indicate that a regeneration is queued.
2. To cancel a queued regeneration, press the Extra Cycle button.

Regenerating Immediately

Press and hold the Extra Cycle button for five seconds.

TIMER OPERATION

Meter Immediate Control

A meter immediate control measures water usage and regenerates the system as soon as the calculated system capacity is depleted. The control calculates the system capacity by dividing the unit capacity (typically expressed in grains/unit volume) by the feedwater hardness and subtracting the reserve. Meter Immediate systems generally do not use a reserve volume. However, in twin tank systems with soft-water regeneration, the reserve capacity should be set to the volume of water used during regeneration to prevent hard water break-through. A Meter Immediate control will also start a regeneration cycle at the programmed regeneration time if a number of days equal to the regeneration day override pass before water usage depletes the calculated system capacity.

Meter Delayed Control

A Meter Delayed Control measures water usage and regenerates the system at the programmed regeneration time after the calculated system capacity is depleted. As with Meter Immediate systems, the control calculates the system capacity by dividing the unit capacity by the feedwater hardness and subtracting the reserve. The reserve should be set to insure that the system delivers treated water between the time the system capacity is depleted and the actual regeneration time. A Meter Delayed control will also start a regeneration cycle at the programmed regeneration time if a number of days equal to the regeneration day override pass before water usage depletes the calculated system capacity.

Time Clock Delayed Control

A Time Clock Delayed Control regenerates the system on a timed interval. The control will initiate a regeneration cycle at the programmed regeneration time when the number of days since the last regeneration equals the regeneration day override value.

Day of the Week Control

This control regenerates the system on a weekly schedule. The schedule is defined in Master Programming by setting each day to either "off" or "on." The control will initiate a regeneration cycle on days that have been set to "on" at the specified regeneration time.

Control Operation During Regeneration

During regeneration, the control displays a special regeneration display. In this display, the control shows the current regeneration step number the valve is advancing to, or has reached, and the time remaining in that step. The step number that displays flashes until the valve completes driving to this regeneration step position. Once all regeneration steps are complete the valve returns to service and resumes normal operation.

Pressing the Extra Cycle button during a regeneration cycle immediately advances the valve to the next cycle step position and resumes normal step timing.

Control Operation During Programming

The control only enters the Program Mode with the valve in service. While in the Program Mode, the control continues to operate normally monitoring water usage and keeping all displays up to date. Control programming is stored in memory permanently, eliminating the need for battery backup power.

Manually Initiating a Regeneration

1. When timer is in service, press the Extra Cycle button for 5 seconds on the main screen.
2. The timer advances to Regeneration Cycle Step #1 (Backwash), and begins programmed time count down.
3. Press the Extra Cycle button once to advance valve to Regeneration Cycle Step #2 (Brine Draw/Rinse).
4. Press the Extra Cycle button once to advance valve to Regeneration Cycle Step #3 (Rapid rinse).
5. Press the Extra Cycle button once to advance valve to Regeneration Cycle Step #4 (Brine Refill).
6. Press the Extra Cycle button once more to advance the valve back to in service.

NOTE: If the unit is a filter or upflow, the cycle step order may change.

NOTE: A queued regeneration can be initiated by pressing the Extra Cycle button. To clear a queued regeneration, press the Extra Cycle button again to cancel. If regeneration occurs for any reason prior to the delayed regeneration time, the manual regeneration request shall be cleared.

Control Operation During A Power Failure

The SXT includes integral power backup. In the event of power failure, the control shifts into a power-saving mode. The control stops monitoring water usage, and the display and motor shut down, but it continues to keep track of the time and day for a minimum of 48 hours.

The system configuration settings are stored in a non-volatile memory and are stored indefinitely with or without line power. The Time of Day flashes when there has been a power failure. Press any button to stop the Time of Day from flashing.

If power fails while the unit is in regeneration, the control will save the current valve position before it shuts down. When power is restored, the control will resume the regeneration cycle from the point where power failed. Note that if power fails during a regeneration cycle, the valve will remain in its current position until power is restored. The valve system should include all required safety components to prevent overflows resulting from a power failure during regeneration.

The control will not start a new regeneration cycle without line power. If the valve misses a scheduled regeneration due to a power failure, it will queue a regeneration. Once power is restored, the control will initiate a regeneration cycle the next time that the Time of Day equals the programmed regeneration time. Typically, this means that the valve will regenerate one day after it was originally scheduled. If the treated water output is important and power interruptions are expected, the system should be setup with a sufficient reserve capacity to compensate for regeneration delays.

MASTER PROGRAMMING MODE CHART

CAUTION Before entering Master Programming, please contact your local professional water dealer. To enter Master Programming, set time to 12:01 PM.

Master Programming Options			
Abbreviation	Parameter	Option Abbreviation	Options
DF	Display Format	GAL	Gallons
		Ltr	Liters
VT	Valve Type	dF1b	Downflow/Upflow Single Backwash
		dF2b	Downflow Double Backwash
		Fltr	Filter
		UFbd	Upflow Brine First
		UFtr	Upflow Filter
		Othr	Other
CT	Control Type	Fd	Meter (Flow) Delayed
		FI	Meter (Flow) Immediate
		tc	Time Clock
		dAY	Day of Week
NT	Number of Tanks	1	Single Tank System
		2	Two Tank System
TS	Tank in Service	U1	Tank 1 in Service
		U2	Tank 2 in Service
C	Unit Capacity		Unit Capacity (Grains)
H	Feedwater Hardness		Hardness of Inlet Water
RS	Reserve Selection	SF	Percentage Safety Factor
		rc	Fixed Reserve Capacity
SF	Safety Factor		Percentage of the system capacity to be used as a reserve
RC	Fixed Reserve Capacity		Fixed volume to be used as a reserve
DO	Day Override		The system's day override setting
RT	Regen Time		The time of day the system will regenerate
BW, BD, RR, BF	Regen Cycle Step Times		The time duration for each regeneration step. Adjustable from OFF and 0-199 minutes. NOTE: If "Othr" is chosen under "Valve Type", then R1, R2, R3, etc, will be displayed instead
D1, D2, D3, D4, D5, D6, & D7	Day of Week Settings		Regeneration setting (On or OFF) for each day of the week on day-of-week systems
CD	Current Day		The current day of the week
FM	Flow Meter Type	P0.7	3/4" Paddle Wheel Meter
		Gen	Generic or Other Meter
		P2.0	2" Paddle Wheel Meter
		t1.5	1.5" Turbine Meter
		P1.5	1.5" Paddle Wheel Meter
		t1.2	1.25" Turbine Wheel Meter
		t1.0	1" Turbine Meter
		P1.0	1" Paddle Wheel Meter
t0.7	3/4" Turbine Meter		
K	Meter Pulse Setting		Meter pulses per gallon for generic/other flow meter

NOTE: Some items may not be shown depending on timer configuration. The timer will discard any changes and exit Master Programming Mode if any button is not pressed for sixty seconds.

MASTER PROGRAMMING MODE

When Master Programming Mode is entered, all available option setting displays may be viewed and set as needed. Depending on current option settings, some parameters cannot be viewed or set.

Setting the Time of Day

1. Press and hold either the Up or Down buttons until the programming icon replaces the service icon and the parameter display reads TD.
2. Adjust the displayed time with the Up and Down buttons.
3. When the desired time is set, press the Extra Cycle button to resume normal operation. The unit will also return to normal operation after five seconds if no buttons are pressed.



Figure 2

Entering Master Programming Mode

Set the Time of Day display to 12:01 P. M. Press the Extra Cycle button (to exit Setting Time of Day mode). Then press and hold the Up and Down buttons together until the programming icon replaces the service icon and the display format screen appears.

Exiting Master Programming Mode

Press the Extra Cycle button to accept the displayed settings and cycle to the next parameter. Press the Extra Cycle button at the last parameter to save all settings and return to normal operation. The control will automatically disregard any programming changes and return to normal operation if it is left in Master Programming mode for 5 minutes without any keypad input.

Resets

Soft Reset

Press and hold the Extra Cycle and Down buttons for 25 seconds while in normal Service mode. This resets all parameters to the system default values. Not reset are the volume remaining in meter immediate or meter delayed systems and days since regeneration in the time clock system.

Master Reset

Hold the Extra Cycle button while powering up the unit. This resets all of the parameters in the unit. Check and verify the choices selected in Master Programming Mode.

1. Display Format (Display Code DF)

This is the first screen that appears when entering Master Programming Mode. The Display Format setting specifies the unit of measure that will be used for volume and how the control will display the Time of Day. This option setting is identified by "DF" in the upper left corner of the screen. There are two possible settings.

Display Format Setting	Unit of Volume	Time Display
GAL	U.S. Gallons	12-Hour AM/PM
Ltr	Liters	24-Hour

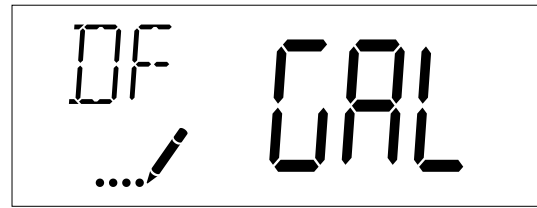

Figure 3

2. Valve Type (Display Code VT)

Press the Extra Cycle button. Use the display to set the Valve Type. 5800 is the only currently available valve type.

3. Regenerant Flow (Display Code RF)

Press the Extra Cycle button. The Regenerant Flow Setting specifies the type of cycle that the valve follows during regeneration. Note that some valve configurations are built with specific subcomponents. Ensure the valve is configured properly before changing the Regenerant Flow setting. This option setting is identified by "RF" in the upper left corner of the screen. There are eight possible settings.

Abbreviation	Parameter
dF1b	Standard Downflow Single Backwash
dF2b	Standard Downflow Double Backwash
Fltr	Filter
dFFF	Downflow Fill First
UFbd	Upflow Brine First
UFFF	Upflow Fill First
UFIt	Upflow Filter
O-dF	Other Downflow
O-UF	Other Upflow

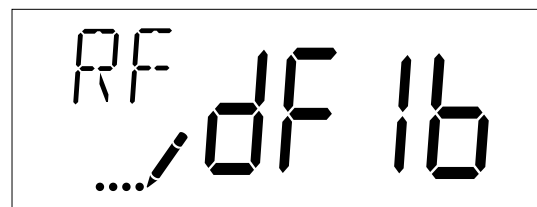

Figure 4

4. Control Type (Display Code CT)

Press the Extra Cycle button. Use this display to set the Control Type. This specifies how the control determines when to trigger a regeneration. For details on how the various options function, refer to the Control Operation section of this service manual. This option setting is identified by "CT" in the upper left corner of the screen. There are four possible settings.

MASTER PROGRAMMING MODE

CONTINUED

Abbreviation	Parameter
Fd	Meter (Flow) Delayed
FI	Meter (Flow) Immediate
tc	Time Clock
dAY	Day of Week

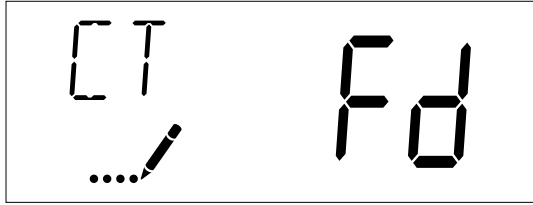

Figure 5

5. Unit Capacity (Display Code C)

Press the Extra Cycle button. Use this display to set the Unit Capacity. This setting specifies the treatment capacity of the system media. Enter the capacity of the media bed in grains of hardness when configuring a softener system, or desired volume capacity when configuring a filter system. This option setting is identified by "C" in the upper left corner of the screen (or by "V" if volume capacity for a filter). The Unit Capacity parameter is only available if the control type has been set to one of the metered options. Use the Up and Down buttons to adjust the value as needed.

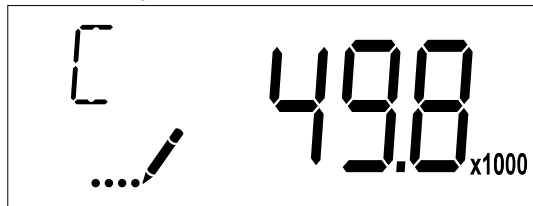

Figure 6

Range: 1-999.9 x 1000 grains/gallon (mg/liter)

6. Feed Water Hardness (Display Code H)

Press the Extra Cycle button. Use this display to set the Feed Water Hardness. Enter the feed water hardness in grains per gallon or degrees for softener systems. This option setting is identified by "H" in the upper left corner of the screen. The feed water hardness parameter is only available if the control type has been set to one of the metered softener options. Use the Up and Down buttons to adjust the value as needed.

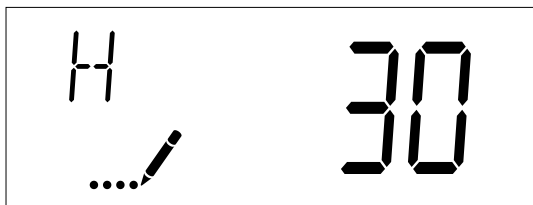

Figure 7

Range: 1-199 grains (degrees)

7. Reserve Selection (Display Code RS)

Press the Extra Cycle button. Use this display to set the Safety Factor and to select the type of reserve to be used in your system. This setting is identified by "RS" in the upper left corner of the screen. The reserve selection parameter is only available if the control type has been set to one of the metered options. There are three possible settings.

Abbreviation	Parameter
SF	Safety Factor
rc	Fixed Reserve Capacity
cr	Variable Reserve

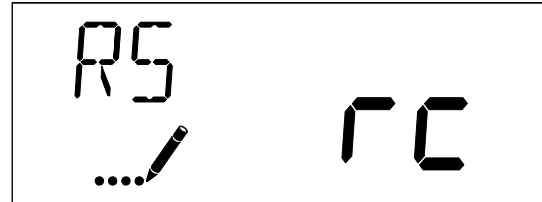

Figure 8

8. Safety Factor (Display Code SF)

Press the Extra Cycle button. Use this display to set the Safety Factor. This setting specifies what percentage of the system capacity will be held as a reserve. Since this value is expressed as a percentage, any change to the unit capacity or feed water hardness that changes the calculated system capacity will result in a corresponding change to the reserve volume. This option setting is identified by "SF" in the upper left corner of the screen. Use the UP and Down buttons to adjust the value from 0 to 50% as needed.

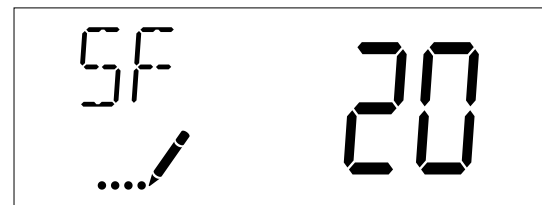

Figure 9

Range: 0-50%

9. Fixed Reserve Capacity (Display Code RC)

Press the Extra Cycle button. Use this display to set the Reserve Capacity. This setting specifies a fixed volume that will be held as a reserve. The Reserve Capacity cannot be set to a value greater than one-half of the calculated system capacity. The Reserve Capacity is a fixed volume and does not change if the unit capacity or feed water hardness are changed. This option setting is identified by "RC" in the upper left corner of the screen. Use the Up and Down buttons to adjust the value as needed.

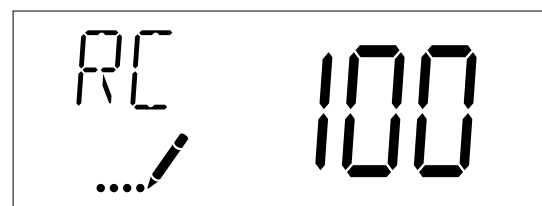

Figure 10

Range: 0-half of the calculated system capacity

MASTER PROGRAMMING MODE

CONTINUED

10. Variable Reserve (Display Code CR)

Press the Extra Cycle button. Use this display to set the Variable Reserve. This setting is formulated to adjust the reserve dependant on the previous calendar day's water usage. During each regeneration, the reserve will change based on the old reserve capacity and the previous day's water usage. This option setting is identified by "CR" in the upper left corner of the screen.



Figure 11

11. Day Override (Display Code D0)

Press the Extra Cycle button. Use this display to set the Day Override. This setting specifies the maximum number of days between regeneration cycles. If the system is set to a timer-type control, the day override setting determines how often the system will regenerate. A metered system will regenerate regardless of usage if the days since last regeneration cycle equal the day override setting. Setting the day override value to "OFF" disables this function. This option setting is identified by "D0" in the upper left corner of the screen. Use the Up and Down buttons to adjust the value as needed.



Figure 12

Range: Off-99 days

12. Regeneration Time

Press the Extra Cycle button. Use this display to set the Regeneration Time. This setting specifies the time of day the control will initiate a delayed, manually queued, or day override regeneration. This option setting is identified by "RT" in the upper left corner of the screen. Use the Up and Down buttons to adjust the value as needed.

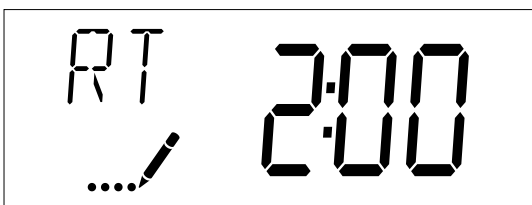

Figure 13

13. Regeneration Cycle Step Times

Press the Extra Cycle button. Use this display to set the Regeneration Cycle Step Times. The different regeneration cycles are listed in sequence based on the valve type selected for the system, and are identified by an abbreviation in the upper left corner of the screen. The abbreviations used are listed below.

Abbreviation	Cycle Step
BD	Brine Draw
BF	Brine Fill
AD	Air Draw
BW	Backwash
RR	Rapid Rinse
SV	Service

If the system has been configured with the "Other" valve type, the regeneration cycles will be identified as C1, C2, ..., C20. Cycle steps can be programmed in any order using the Up or Down buttons with the following selections. Up to 20 individual cycles can be set. Time for each cycle can be set from 0 to 199 minutes. Setting a cycle step time to 0 will cause the control to skip that step during regeneration, but keeps the following steps available. Use the Up and Down buttons to adjust the value as needed. Press the Extra Cycle button to accept the current setting and move to the next parameter. Program the last cycle step as LC which forces the valve back to the service position.

Abbreviation	Cycle Step
RR	Rapid Rinse
BD	Brine Draw
SR	Slow Rinse
BW	Backwash
RF	Refill
SP	Service Position
LC	Last Cycle



Figure 14

Range: 0-199 minutes

14. Day of Week Settings

Press the Extra Cycle button. Use this display to set the regeneration schedule for a system configured as Day of Week control. The different days of the week are identified as D1, D2, D3, D4, D5, D6, and D7 in the upper left corner of the display. Set the value to "ON" to schedule a regeneration or "OFF" to skip regeneration for each day. Use the Up and Down buttons to adjust the setting as needed. Press the Extra Cycle button to accept the setting and move to the next day. Note that the control requires at least one day to be set to "ON". If all 7 days are set to "Off", the unit will return to Day 1 until one or more days are set to "ON".

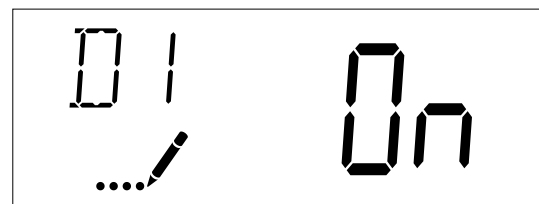

Figure 15

MASTER PROGRAMMING MODE

CONTINUED

15. Current Day (Display Code CD)

Press the Extra Cycle button. Use this display to set the current day on systems that have been configured as Day of Week controls. This setting is identified by "CD" in the upper left corner of the screen. Use the Up and Down buttons to select from Day 1 through Day 7.

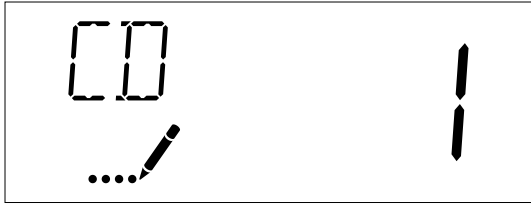

Figure 16

16. Flow Meter Type (Display Code FM)

Press the Extra Cycle button. Use this display to set the type of flow meter connected to the control. This option setting is identified by "FM" in the upper left corner of the screen. Use the Up and Down buttons to select one of the eight available settings.

Abbreviation	Description
P0.7	3/4" Paddle Wheel Meter
t0.7	3/4" Turbine Meter
P1.0	1" Paddle Wheel Meter
t1.0	1" Turbine Meter
P1.5	1.5" Paddle Wheel Meter
t1.5	1.5" Turbine Meter
P2.0	2" Paddle Wheel Meter
Gen	Generic or Other non-Fleck Meter
t1.2	1.25" Turbine Meter

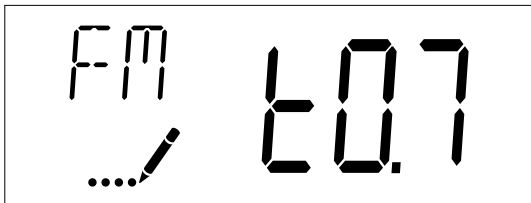

Figure 17

17. Meter Pulse Setting (Display Code K)

Press the Extra Cycle button. Use this display to specify the meter pulse setting for a non-standard flow meter. This option setting is identified by "K" in the upper left corner of the screen. Use the Up and Down buttons to enter the meter constant in pulses per unit volume.



Figure 18

K Range: 0.1 to 999.9 pulses per gallon.

18. Relay Setting (Display Code RE)

Press the Extra Cycle button. Use this display to enable the relay output. This option setting is identified by "RE" in the upper left corner of the screen. Use the Up and Down buttons to enable the relay using either time based (tb) or flow based (Fb). **Only one method can be used at a time.**

For time based, set the desired Start Time (ST) and End Time (ET). Time ranges available are determined by the Regen Cycle Step Times. For flow based, set the desired Volume Interval (VO) and Time On (TO).

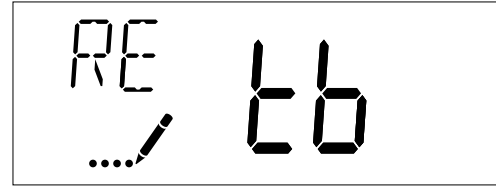

Figure 19

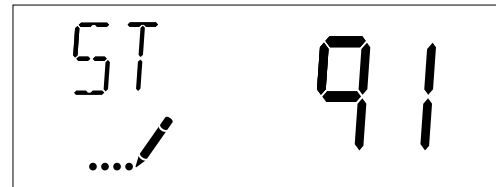

Figure 20

ST Range: 0 to total number of cycles minus 1

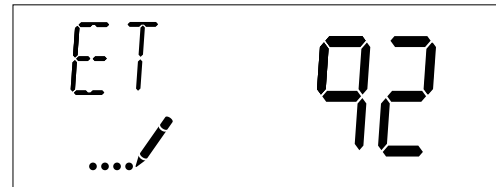

Figure 21

ET Range: Start time to total of all cycles

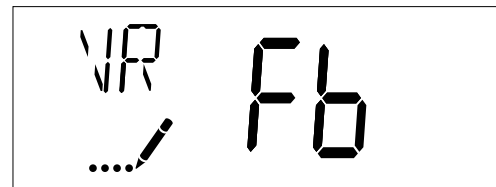

Figure 22



Figure 23

VO Range: 1 to Total Gallon Capacity

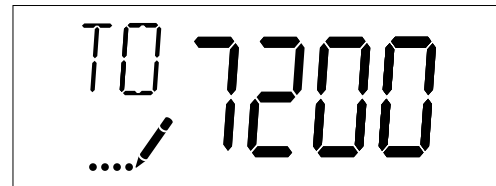

Figure 24

TO Range: 1 to 7200 (minutes)

19. End of Master Programming Mode

Press the Extra Cycle button to save all settings and exit Master Programming Mode.

VIEWING DIAGNOSTIC DATA

The SXT control records and maintains diagnostic data to assist with servicing and troubleshooting the water treatment system.

Abbreviation	Parameter	Description
FR	Flow Rate	Displays the current outlet flow rate.
PF	Peak Flow Rate	Displays the highest flow rate measured since last regeneration.
HR	Hours in Service	Displays the total hours that the unit has been in service since last regeneration.
VU	Volume Used	Displays the total volume of water treated by the unit since last regeneration.
RC	Reserve Capacity	Displays the system's reserve capacity calculated from the system capacity, feed water hardness, and safety factor.
TV	Totalizer Volume	Displays the total volume of water used by the unit since last installation or last reset.
SV	Software Version	Displays the software version installed on the controller.

NOTE: Some items may not be shown depending on control configuration. The control will discard any changes and exit the Diagnostics View if a button is not pressed for 60 seconds.

Diagnostics View Steps

1. Press the Up and Extra Cycle buttons for five seconds while in service.
2. Use this display to view the current Flow Rate. This option setting is identified by "FR" in the upper left corner of the screen.

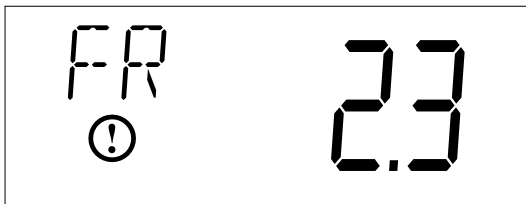

Figure 25

3. Press the Up button. Use this display to view the Peak Flow Rate since the last regeneration cycle. This option setting is identified by "PF" in the upper left corner of the screen.



Figure 26

4. Press the Up button. Use this display to view the Hours in Service since the last regeneration cycle. This option setting is identified by "HR" in the upper left corner of the screen.



Figure 27

5. Press the Up button. Use this display to view the Volume Used since the last regeneration cycle. This option setting is identified by "VU" in the upper left corner of the screen.

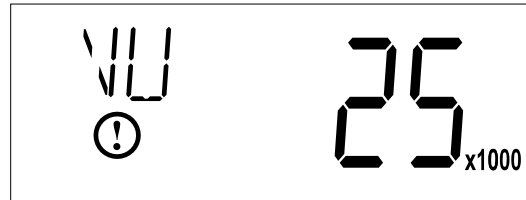

Figure 28

6. Press the Up button. Use this display to view the Reserve Capacity. This option setting is identified by "RC" in the upper left corner of the screen.



Figure 29

7. Press the Up button. Use this display to view the Total Volume data. This option is identified by "TV" in the upper left corner of the screen.

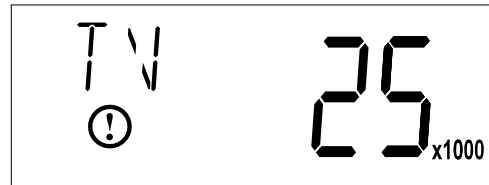

8. Press the Up button. Use this display to view the Software Version. This option setting is identified by "SV" in the upper left corner of the screen.

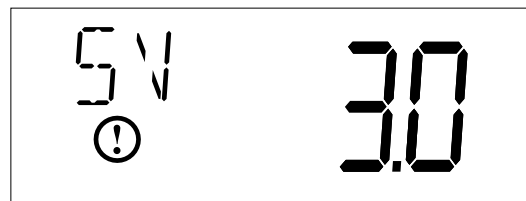
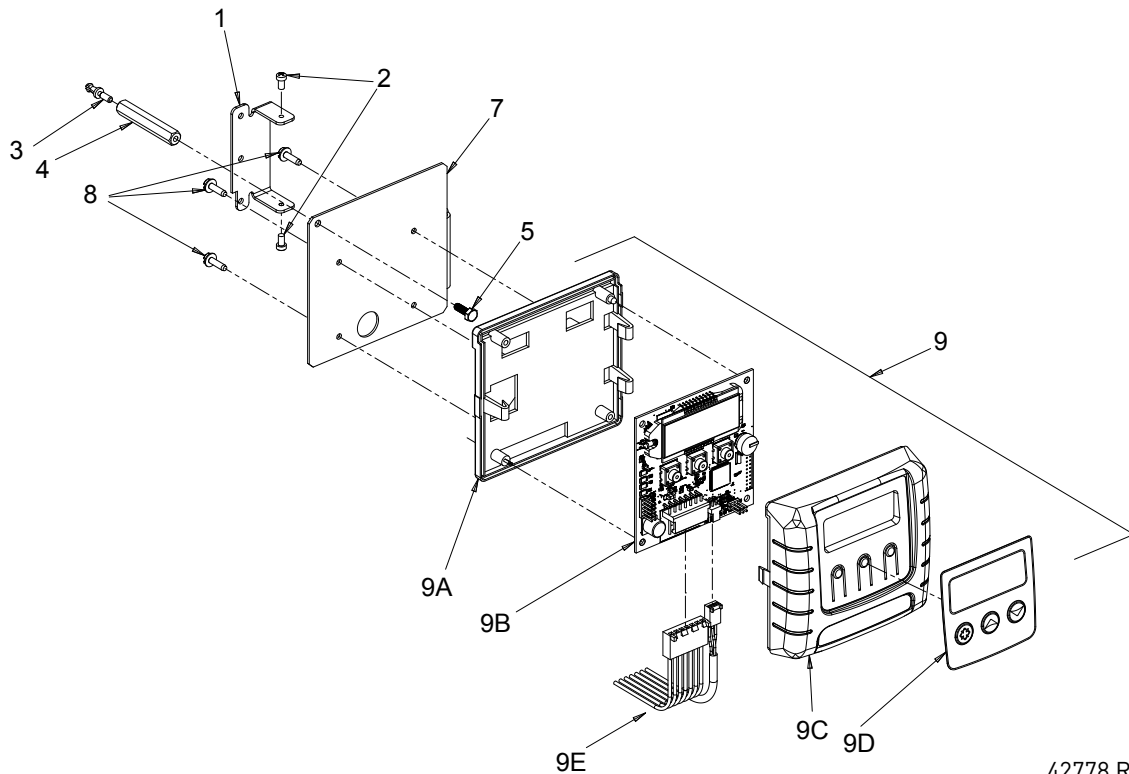

Figure 30

9. Press the Extra Cycle button to end Diagnostic Programming Mode.

2510/2750/2850S TIMER ASSEMBLY



42778 Rev E

Item No.	QTY	Part No.	Description
1	1	13881	Bracket, Hinge Timer
3	1	14265	Clip, Spring
4	1	27172	Stand-off, Timer, 2510SXT, 2750SXT
5	1	21363	Screw, Hex HD, M4 X 12 MM
7	1	27168	Bracket, Timer, 2510SE/2750SXT
8	3	13296	Screw, Hex Washer, 6-20 X 1/2
9	1	42778	Timer, SXT, 2510/2750, DF
9A	1	19889	Housing, Circuit Board
9B	1	42196	Circuit Board, SXT
9C	1	42635-01	Cover, Front, SXT, Square
9D	1	42637	Label, Display, SXT
9E	1	42864	Wire Harness, SXT

Not Shown:

.....	44144	Transformer, US, 120/24V, 40VA, CEC
.....	43340	Transformer, Japan, 100/24V, 40 VA

9000/9100/9500 TWIN TANK TIMER

ASSEMBLY

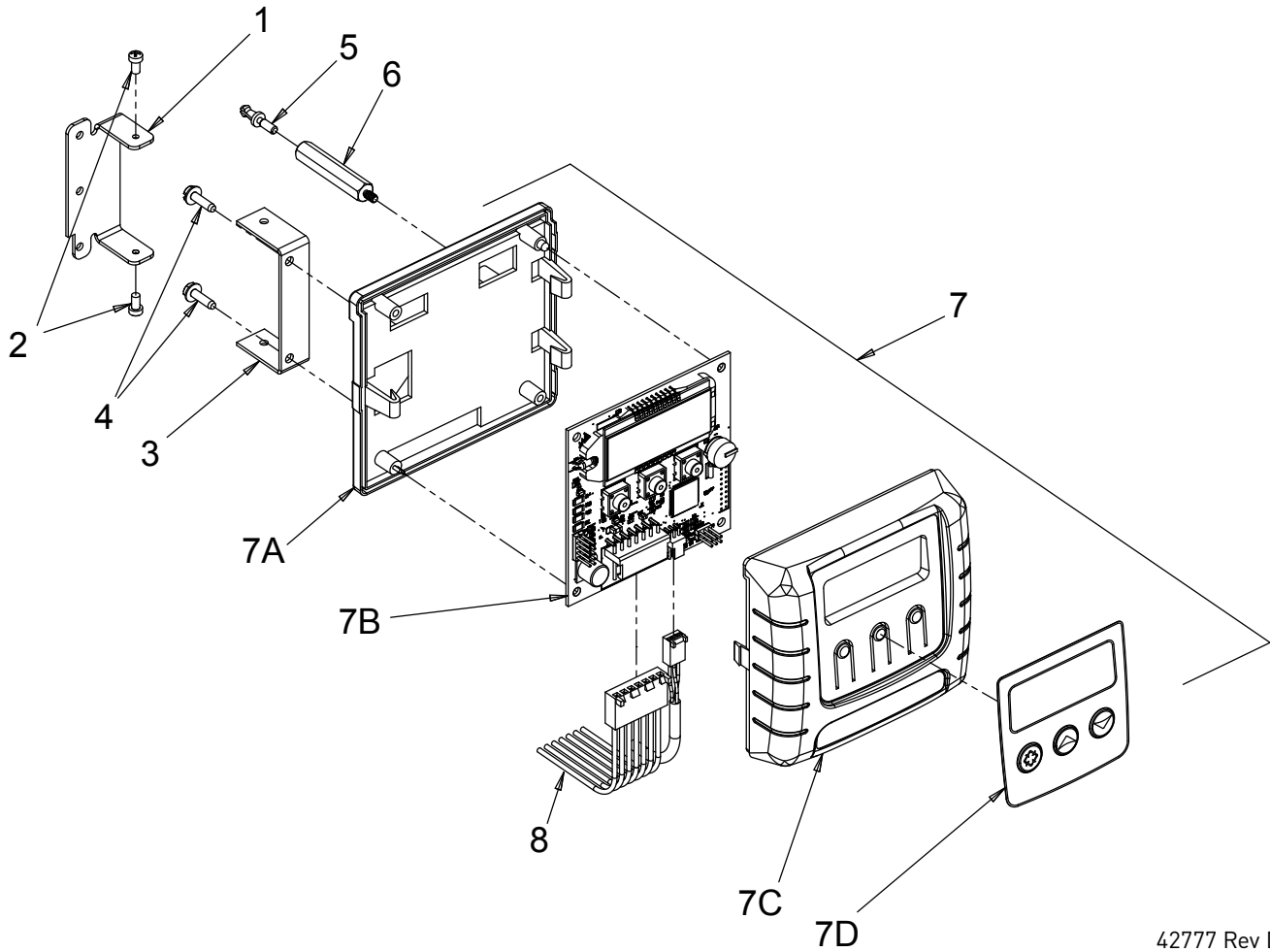

42777 Rev D

Item No.	QTY	Part No.	Description
1	1	13881	Bracket, Hinge Timer
2	2	11384	Screw, Phillips, 6-32 X 1/4
3	1	42732	Bracket, Timer, 9000SXT
4	2	13296	Screw, Hex Washer Hd, 6-20 X 1/2
5	1	14265	Clip, Spring
6	1	42733	Stand-off, Timer, 9000SXT
7	1	42777	Timer, SXT, D/F, 9000/9100/9500
7A	1	19889	Housing, Circuit Board
7B	1	42196	Circuit Board, SXT
7C	1	42635-01	Cover, Front, SXT, Square
7D	1	42637	Label, Display, SXT
8	1	19474-01	Harness, SXT

Not Shown:

.....	44147	Transformer, US, 120/24V, 9.6VA
.....	41475	Transformer, Euro, 230/24V, 9.6VA
.....	43212	Transformer, Aust, 230/24V, 9.6VA
.....	43340	Transformer, Japan, 100/24V, 9.6VA

3/4-INCH PLASTIC TURBINE METER ASSEMBLY

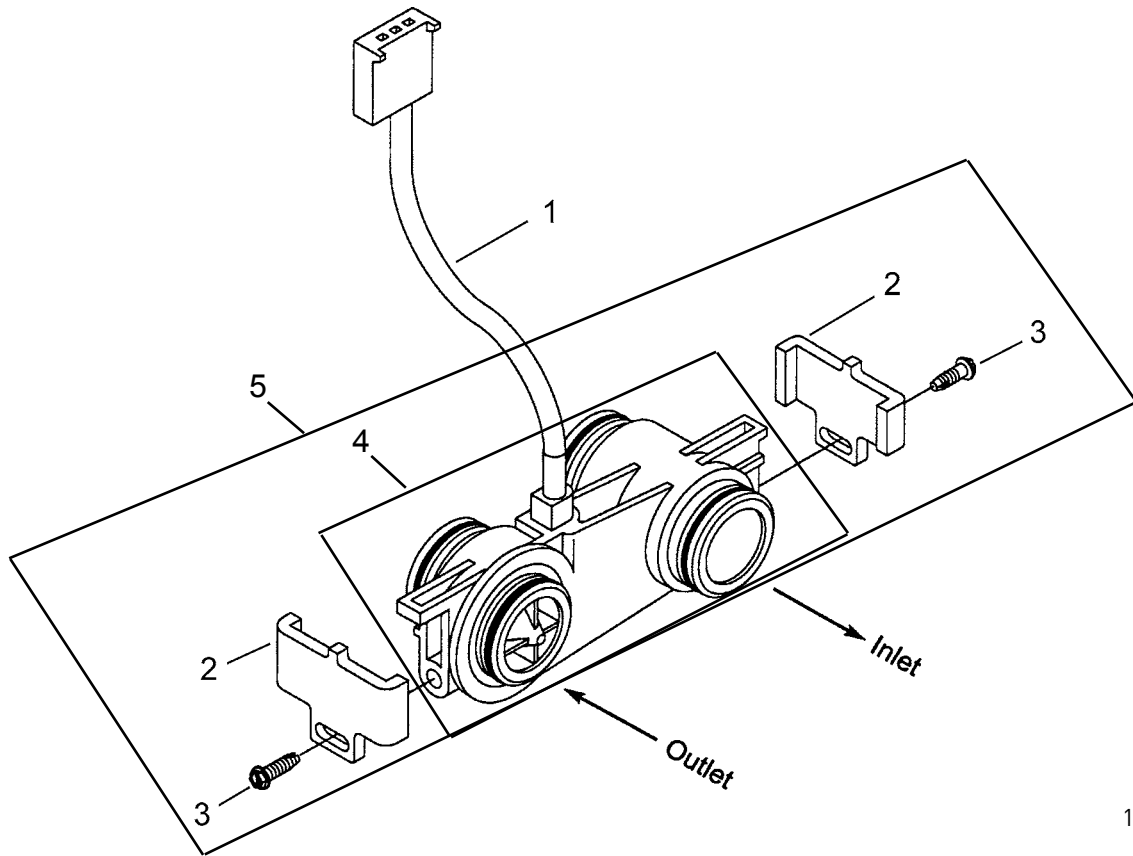

19797 Rev A

Item No.	QTY	Part No.	Description
1	1	19791-01	Meter Cable Assembly, 16 inch long with connector
2	2	19569	Clip, Flow Meter
3	2	13314	Screw, Slot Ind Hex, 8-18 x .60
4		19797	Meter, 3/4" Turbine, No Clips/Screws
5		60626	Meter, 3/4" Turbine, with Clips/Screws

PLASTIC PADDLE METER ASSEMBLY

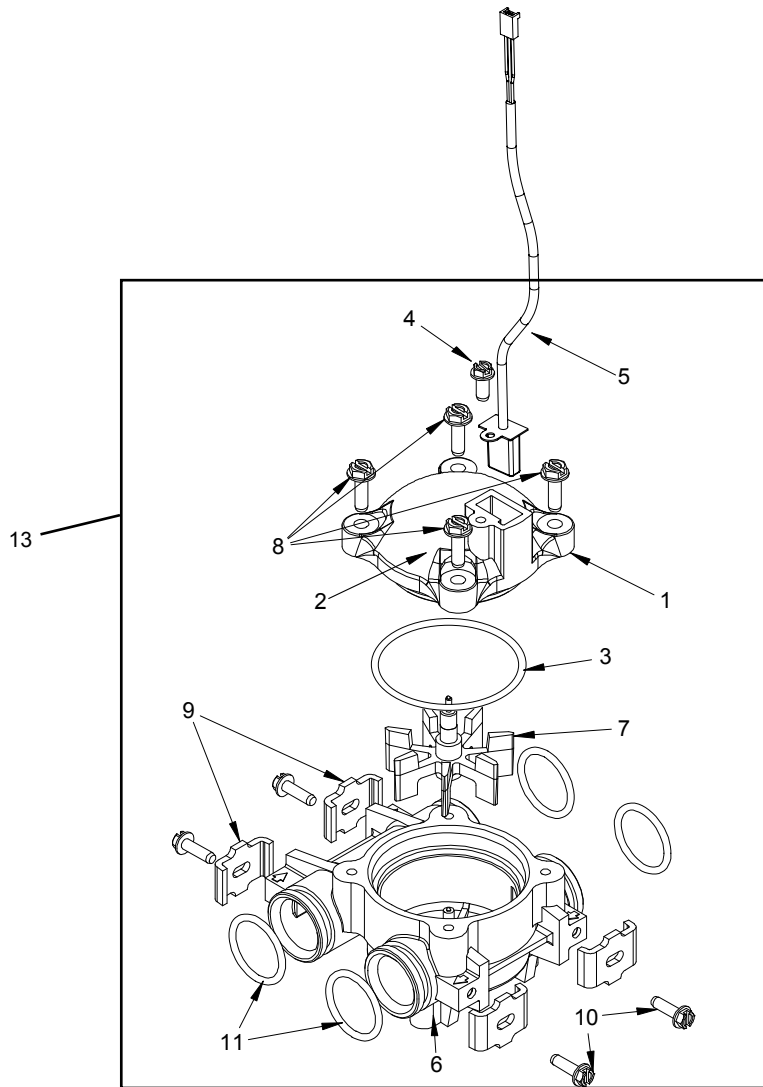

BR60086 Rev E

Item No.	QTY	Part No.	Description
1	1	14716	Meter Cap Assy, NT (includes items 2, 3, and 4)
2	1	13874	Cap, Meter, Electronic
3	1	13847	O-ring, -137, Std, Meter
4	1	17798	Screw, Slot Hex Washer Head
5	1	19121-01	Meter Cable Assy, SXT, Paddle (not included in P/N 60086-50)
6	1	13821	Body, Meter, 5600
7	1	13509	Impeller, Meter
8	4	12473	Screw, Hex Wsh, 10-24 x 5/8
9	4	13255	Clip, Mounting
10	4	13314	Screw, Slot Ind Hex, 8-18 x 0.60
11	4	13305	O-ring, -119
12	1	14613	Flow Straightener
13	1	60086-50	Meter, 3/4", Paddlewheel, Electronic

3/4-INCH BRASS PADDLE METER ASSEMBLY

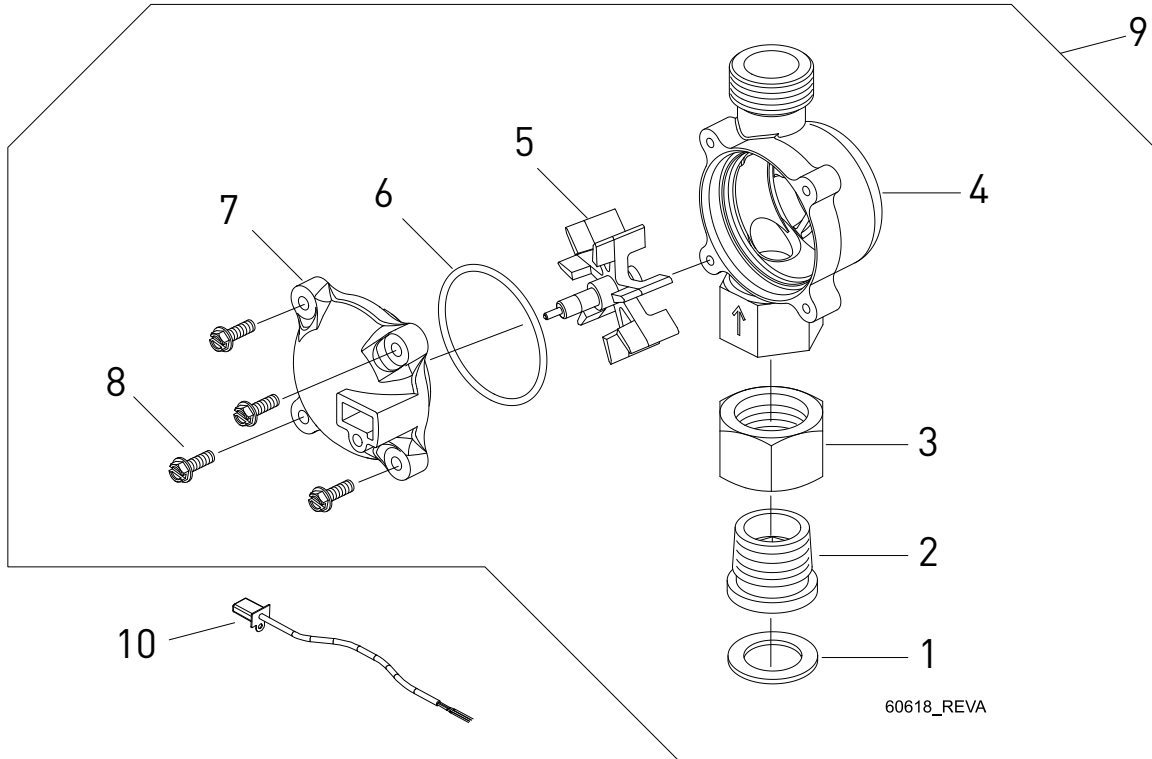

Item No.	QTY	Part No.	Description
1	1	11206	Gasket, Fitting
2	1	13942	Retainer, Nut
3	1	11207	Nut, Special, Quick Connect
4	1	13906	Body, Meter, 3/4-inch
5	1	13509	Impeller, Meter
		13509-01	Impeller, Celcon
6	1	13847	O-ring, -137 Std/560CD, Meter
7	1	14716	Meter Cap Assy, ET/NT
8	1	12473	Screw, Hex Wsh, 10-24 x 5/8
9	1	60618	Meter Assy, 3/4", Brass, Elec, Paddlewheel
10	1	19121-01	Meter Cable Assembly, 18 inch long with connector

1-INCH BRASS PADDLE METER ASSEMBLY

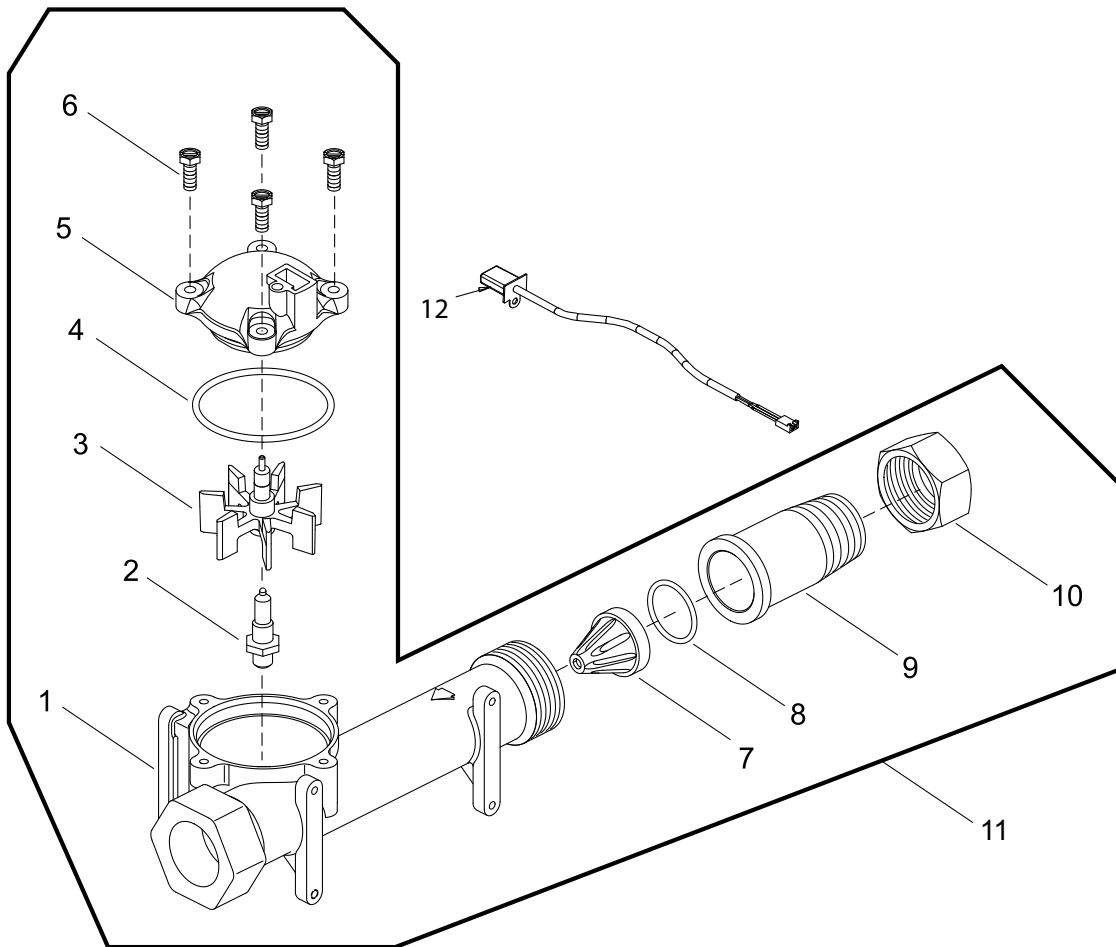

Item No.	QTY	Part No.	Description
1	1	14959	Body, Meter, 2750
2	1	13882	Post, Meter Impeller
3	1	13509	Impeller, Meter
4	1	13847	O-ring, -137, Std/560CD, Meter
5	1	14716	Meter Cap Assy, ET/NT
6	4	12112	Screw, Hex Hd Mach, 10-24 x 1/2
7	1	14960	Flow Straightener, 1-inch
8	1	13287	O-ring, -123
9	1	14961	Fitting, 1-inch Quick Connect
10	1	14962	Nut, 1-inch Meter, Quick Connect
11	1	60613	Meter Assy, 1", Brass, Elec, Paddlewheel
12	1	19121	Meter Cable Assembly
		19121-08	Meter Cable Assembly, 35 inch long with connector
		19121-09	Meter Cable Assembly, 100 inch long with connector
		19121-10	Meter Cable Assembly, 304 inch long with connector

1-INCH STAINLESS STEEL METER ASSEMBLY

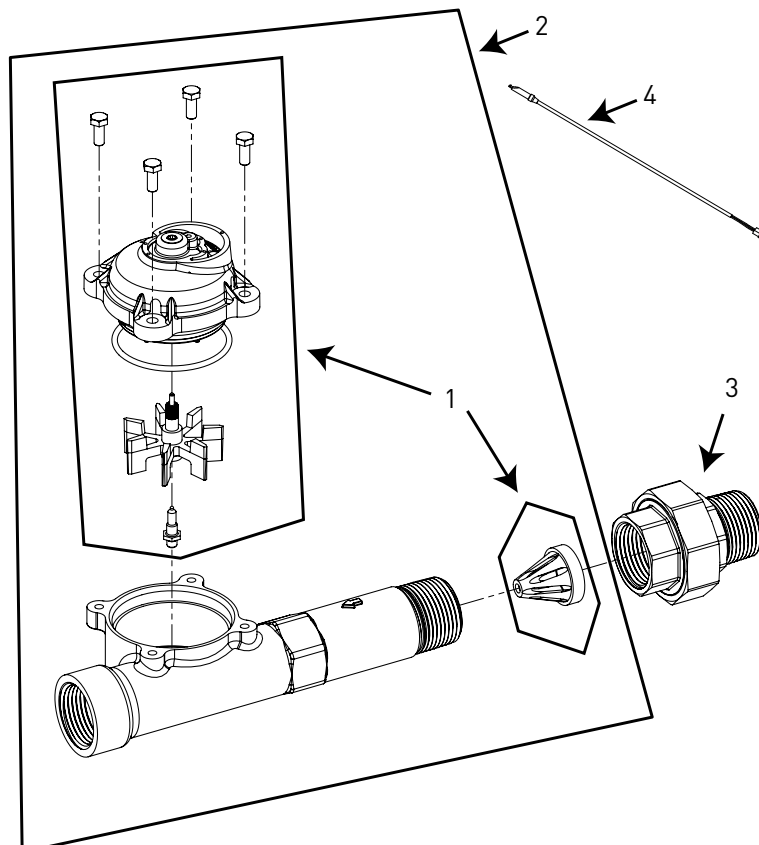

Item No.	QTY	Part No.	Description
1	1	62049-01	Service Kit, 1 inch & 1-1/2 inch Meter, Standard Range
1	1	62049-02	Service Kit, 1 inch & 1-1/2 inch Meter, Extended Range
2	1	61932-10	Meter Assy, 1 inch, Inline, Stainless Steel, NPT, Standard Range
1	1	61932-11	Meter Assy, 1 inch, Inline, Stainless Steel, NPT, Extended Range
1	1	61932-20	Meter Assy, 1 inch, Inline, Stainless Steel, BSP, Standard Range
1	1	61932-21	Meter Assy, 1 inch, Inline, Stainless Steel, BSP, Extended Range
3	1	44022	Union, 1 inch, NPT (Optional on models with electronic controls)
1	1	44023	Union, 1 inch, BSP (Optional on models with electronic controls)

Item No.	QTY	Part No.	Description
4	1	19791	Meter Cable Assembly
		19791-02	Meter Cable Assembly, 28 inch long with connector
		19791-04	Meter Cable Assembly, 100 inch long with connector
		19791-05	Meter Cable Assembly, 304 inch long with connector

INLINE PLASTIC TURBINE METER ASSEMBLY

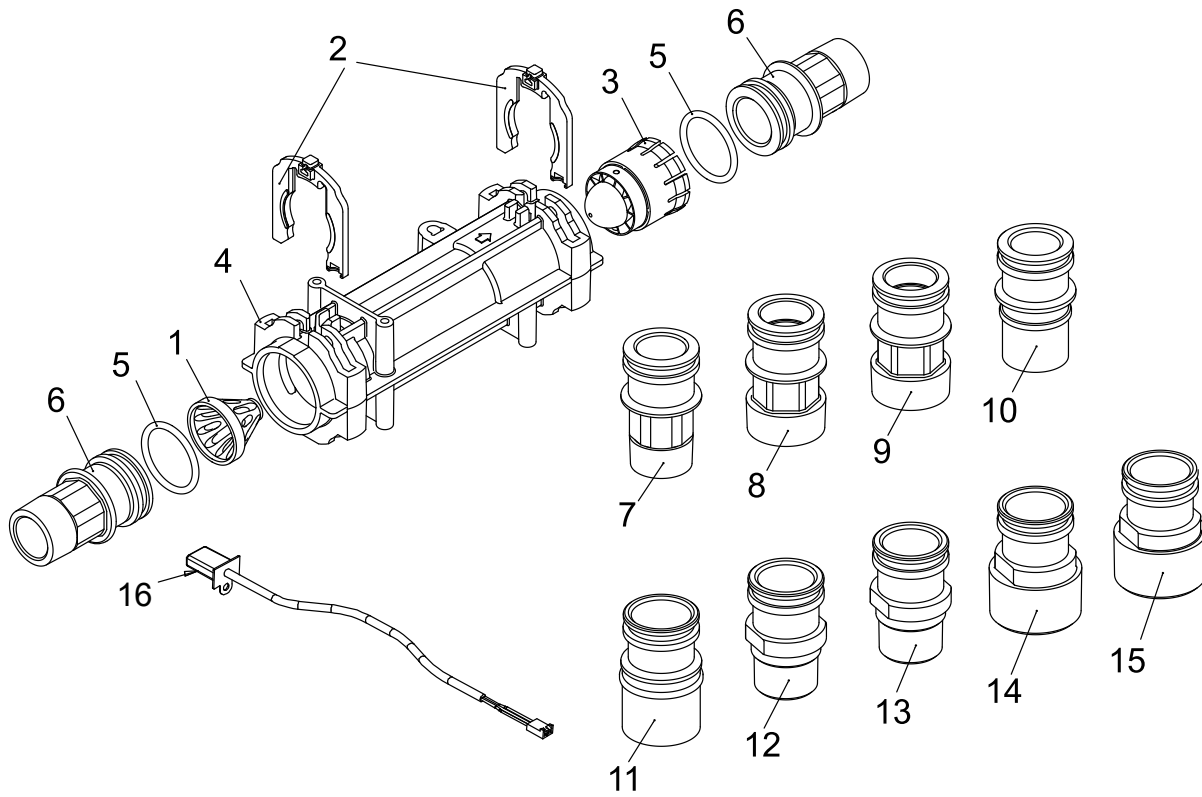

Item No.	QTY	Part No.	Description
1	1	17542	Flow Straightener
2	2	40576	Clip, H, Plastic, 7000
3	1	40577	Turbine Meter Assy, 7000
4	1	41555	Body, Remote Meter
5	2	40951	O-ring, -220
6	2	40563	Connector, 1-inch NPT, 7000
7	2	40563-10	Connector, 1-inch BSP, 7000
8	2	40565	Connector, 1-1/4 inch NPT, 7000
9	2	40565-10	Connector, 1-1/4 inch BSP, 7000
10	2	41242	Connector, 1-inch & 1-1/4 inch Sweat
11	2	41243	Connector, 1-1/4 & 1-1/2 inch Sweat
12	2	41596	Connector, Brass, 1-inch NPT
13	2	41596-10	Connector, Brass, 1-inch BSP
14	2	41597	Connector, Brass, 1-1/2 inch NPT
15	2	41597-10	Connector, Brass, 1-1/2 inch BSP

Item No.	QTY	Part No.	Description
16	1	19791	Meter Cable Assembly
		19791-02	Meter Cable Assembly, 28 inch long with connector
		19791-04	Meter Cable Assembly, 100 inch long with connector
		19791-05	Meter Cable Assembly, 304 inch long with connector

Not Shown

.....	61560	Meter Assy, 1-1/2", InLn, No Thrd
.....	61560-01	Meter Assy, 1", NPT, Elec
.....	61560-02	Meter Assy, 1", InLn, BSP, Elec
.....	61560-03	Meter Assy, 1-1/4", InLn, NPT, Elec
.....	61560-04	Meter Assy, 1-1/4", InLn, BSP, Elec
.....	61560-05	Meter Assy, 1" & 1-1/4", InLn, Sweat
.....	61560-06	Meter Assy, 1-1/4" & 1-1/2", InLn
.....	61560-07	Meter Assy, 1", InLn, NPT, Elec
.....	61560-08	Meter Assy, 1", InLn, BSP, Elec
.....	61560-09	Meter Assy, 1-1/2" InLn, NPT, Elec
.....	61560-10	Meter Assy, 1-1/2", InLn, BSP, Elec
.....	61560-11	Meter Assy, 3/4", InLn, NPT, Elec
.....	61560-12	Meter Assy, 3/4", InLn, BSP, Elec
.....	61560-13	Meter Assy, 1-1/2", InLn, NPT
.....	61560-14	Meter Assy, 1-1/2", InLn, BSP

1-1/2 INCH BRASS METER ASSEMBLY

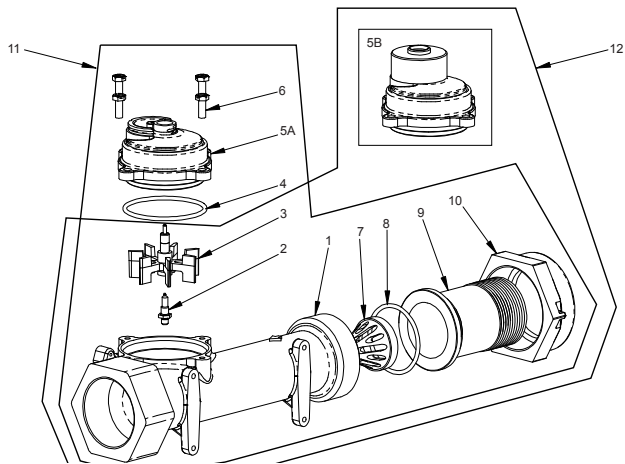

Item No.	QTY	Part No.	Description
1	1	17569	Body, Meter, 2850/9500
2	1	13882	Post, Meter Impeller
3	1	13509	Impeller, Meter
	1	13509-01	Impeller, Celcon, Hot Water
4	1	13847	O-Ring, -137, Std/560CD, Meter
5A	1	14038	Meter Cap Assy, STD Range, Plastic
5B	1	15150	Meter Cap Assy, Ext Range, Plastic
6	4	12112	Screw, Hex Hd Mach, 10-24 x 1/2 18-8 Stainless Steel
7	1	17542	Flow Straightener, 1-1/2 inch
8	1	12733	O-Ring, -132
9	1	17544	Fitting, 1-1/2 inch Quick Connector
10	1	17543	Nut, 1-1/2 inch, Q/C
11		60610-01	Meter Assy, 1-1/2 inch, NPT, STD, Brass, Paddlewheel
		60610-01NP	Meter Assy, 1-1/2 inch Inline, NPT, STD Brass Body, Nickel Plated, Paddlewheel
		60610-01HW	Meter Assy, 1-1/2 inch Inline, NPT, STD Brass, Hot Water, Paddlewheel
		60610-21	Meter Assy, 1-1/2 inch, BSP, STD, Brass, Paddlewheel
		60610-21NP	Meter Assy, 1-1/2 inch Inline, BSP, STD, Brass Body, Nickel Plated, Paddlewheel
		60611-01	Meter Assy, 1-1/2 inch Inline, NPT, STD, Brass Body, Paddlewheel, Sleeve to 1-inch
		60611-01NP	Meter Assy, 1-1/2 inch Inline, NPT, STD Nickel Plated, Paddlewheel, Sleeve to 1-inch

Item No.	QTY	Part No.	Description
		60611-23	Meter Assy, 1-1/2 inch Inline, BSP, STD, Paddlewheel, Sleeve to 1-inch
		60611-23NP	Meter Assy, 1-1/2 inch Inline, BSP/MET STD, Nickel Plated, Paddlewheel, 1-inch Sleeve
12		60610-02	Meter Assy, 1-1/2 inch, NPT, STD, Brass Paddlewheel
		60610-02NP	Meter Assy, 1-1/2 inch Inline, NPT, EXT Nickel Plate, Paddlewheel
		60610-02HW	Meter Assy, 1-1/2 inch Inline, NPT, EXT Brass, Hot Water, Paddlewheel
		60610-22	Meter Assy, 1-1/2 inch, BSP, EXT, Brass, Paddlewheel
		60610-22NP	Meter Assy, 1-1/2 inch Inline, BSP EXT, Brass Body, Nickel Plate, Paddlewheel
		60611-02	Meter Assy, 1-1/2 inch Inline, NPT, EXT Brass Body, Paddlewheel, Sleeve to 1-inch
		60611-02NP	Meter Assy, 1-1/2 inch Inline, NPT, EXT Nickel Plated, Paddlewheel, Sleeve to 1-inch
		60611-22	Meter Assy, 1-1/2 inch Inline, BSP, EXT Brass Body, Paddlewheel, Sleeve to 1-inch
		60611-22NP	Meter Assy, 1-1/2 inch Inline, BSP, EXT, Nickel, Paddlewheel, Sleeve to 1-inch
13	1	19121	Meter Cable Assembly
		19121-08	Meter Cable Assembly, 35 inch long with connector
		19121-09	Meter Cable Assembly, 100 inch long with connector
		19121-10	Meter Cable Assembly, 304 inch long with connector
Not Shown			
	1	17790	Sleeve, Meter, 1 1/2 inch x 1-inch
	1	15218	Meter Cap Assy, STD Range, Brass, Hot Water
	1	15237	Meter Cap Assy, EXT Range, Brass, Hot Water

1-1/2 INCH STAINLESS STEEL METER ASSEMBLY

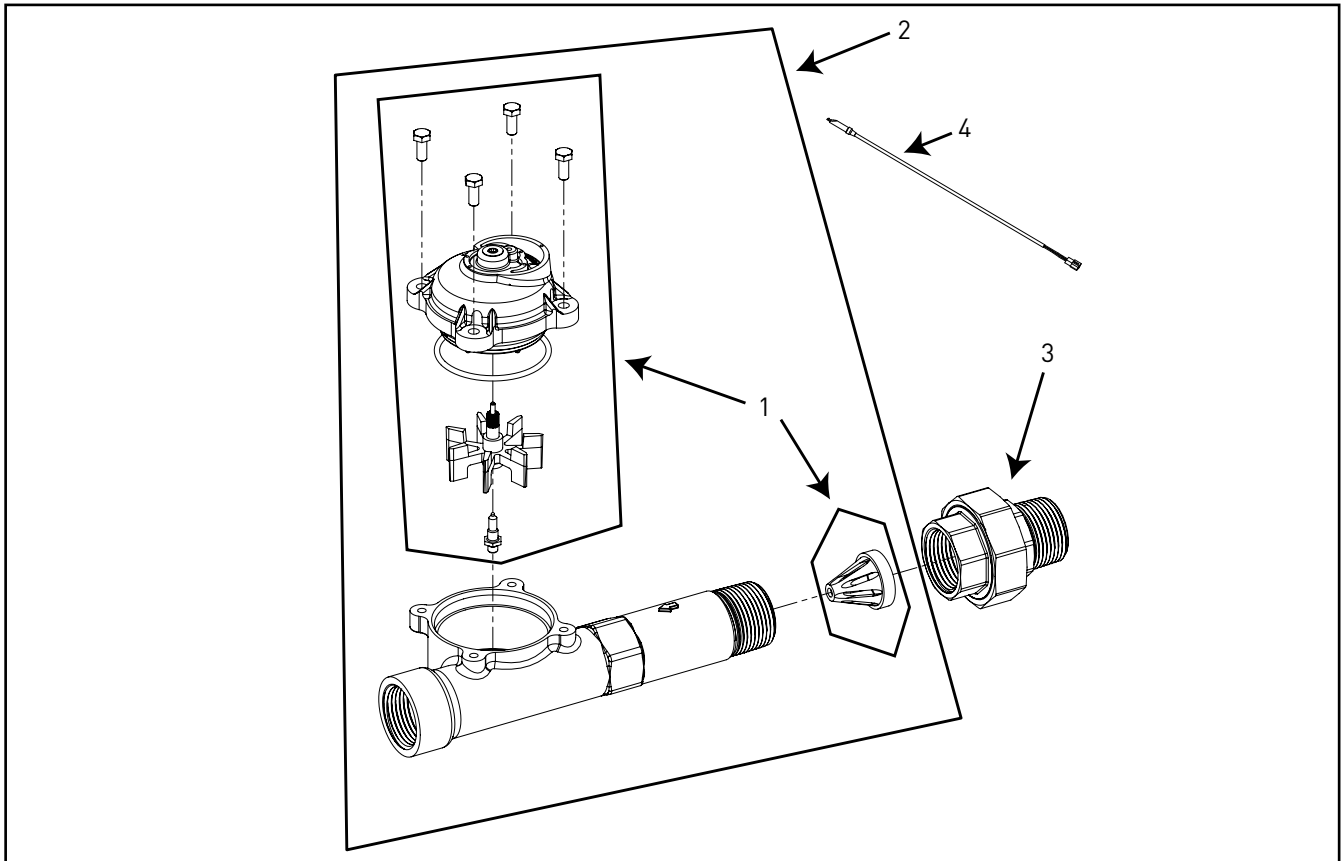

Item No.	QTY	Part No.	Description
1	1	62049-01	Service Kit, 1 inch & 1-1/2 inch Meter, Standard Range
1	1	62049-02	Service Kit, 1 inch & 1-1/2 inch Meter, Extended Range
2	1	61933-10	Meter Assy, 1-1/2 inch, Inline, Stainless Steel, NPT, Standard Range
1	1	61933-11	Meter Assy, 1-1/2 inch, Inline, Stainless Steel, NPT, Extended Range
1	1	61933-20	Meter Assy, 1-1/2 inch, Inline, Stainless Steel, BSP, Standard Range
1	1	61933-21	Meter Assy, 1-1/2 inch, Inline, Stainless Steel, BSP, Extended Range
3	1	44024	Union, 1-1/2 inch, NPT (Optional on models with electronic controls)
1	1	44025	Union, 1-1/2 inch, BSP (Optional on models with electronic controls)

Item No.	QTY	Part No.	Description
4	1	19791	Meter Cable Assembly
		19791-02	Meter Cable Assembly, 28 inch long with connector
		19791-04	Meter Cable Assembly, 100 inch long with connector
		19791-05	Meter Cable Assembly, 304 inch long with connector
Not Shown (optional)			
1	1	62072	Meter Sleeve, 1-1/2 inch to 1 inch (optional)

**3/4-INCH, 1-INCH OR 1-1/2 INCH PADDLE
WHEEL METER CAP ASSEMBLY**

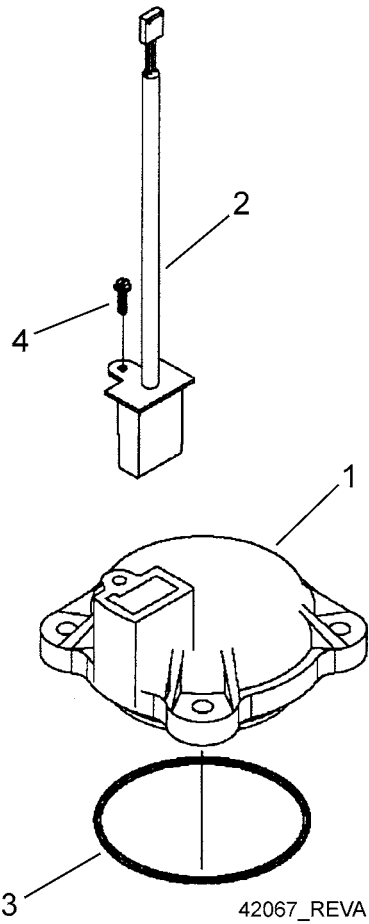

42067_REVA

Item No.	QTY	Part No.	Description
1	1	14716	Meter Cap Assy, NT
2	1	19121-01	Meter Cable Assy, SXT, Paddle 6700XTR
		19121-08	Meter Cable Assy, NT, 35-inch w/Connector
		19121-09	Meter Cable Assy, NT, 99.5-inch w/Connector
		19121-10	Meter Cable Assy, NT, 303.5-inch w/Connector
3	1	13847	O-ring, -137, Std/560CD, Meter
4	1	17798	Screw, Slot Hex Wsh Hd

TROUBLESHOOTING

Error Codes

NOTE: Error codes appear on the In Service display.

Error Code	Error Type	Cause	Reset and Recovery
0	Cam Sense Error	The valve drive took longer than 6 minutes to advance to the next regeneration position	Unplug the unit and examine the powerhead. Verify that all cam switches are connected to the circuit board and functioning properly. Verify that the motor and drive train components are in good condition and assembled properly. Check the valve and verify that the piston travels freely. Replace/reassemble the various components as necessary. Plug the unit back in and observe its behavior. The unit should cycle to the next valve position and stop. If the error re-occurs, unplug the unit and contact technical support.
1	Cycle Step Error	The control experienced an unexpected cycle input	Unplug the unit and examine the powerhead. Verify that all cam switches are connected to the circuit board and functioning properly. Enter Master Programming mode and verify that the valve type and system type are set correctly with regard to the unit itself. Step the unit through a manual regeneration and verify that it functions correctly. If the error re-occurs unplug the unit and contact technical support.
2	Regen Failure	The system has not regenerated for more than 99 days (or 7 days if the Control Type has been set to Day-of-Week)	Perform a Manual Regeneration to reset the error code. If the system is metered, verify that it is measuring flow by running service water and watching for the flow indicator on the display. If the unit does not measure flow, verify that the meter cable is connected properly and that the meter is functioning properly. Enter a Master Programming Mode and verify that the unit is configured properly. As appropriate for the valve configuration, check that the correct system capacity has been selected, that the day override is set properly, and that meter is identified correctly. If the unit is configured as a Day-of-Week system, verify that at least one day is set ON. Correct the settings as necessary.
3	Memory Error	Control board memory failure	Perform a Master Reset and reconfigure the system via Master Programming Mode. After reconfiguring the system, step the valve through a manual regeneration. If the error re-occurs unplug the unit and contact technical support.
UD	Upper Drive Sync	Power failure install programming change	Valve will automatically recover.

2510SXT WIRING DIAGRAM

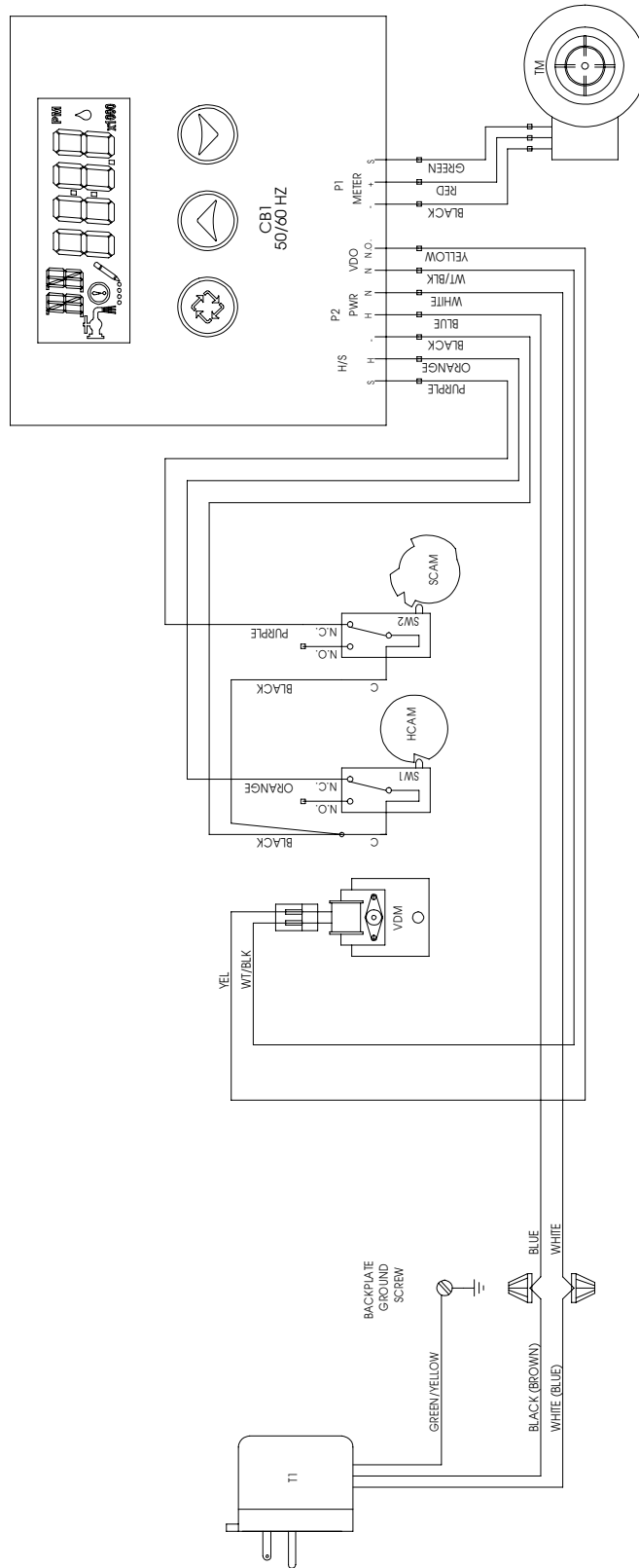

NOTE: DEPENDING ON APPLICATION, VALVE STEP CAM APPEARANCE WILL VARY. REGARDLESS OF CAM TYPE USED, WIRING TO SWITCHES SW1 AND SW2 WILL REMAIN AS SHOWN.

1. VALVE SHOWN IN SERVICE POSITION.
- 2.
- 3.

- CBI - SXT TIMER
- T1 - 24VAC TRANSFORMER
- K1 - 24VAC VALVE DRIVE RELAY
- TM - 3/4" TURBINE FLOW METER (OPTIONAL)
- VDM - VALVE DRIVE MOTOR
- SW1 - VALVE HOMING SWITCH
- SW2 - VALVE STEP SWITCH
- HCAM - VALVE HOMING CAM
- SCAM - VALVE STEP CAM

42741 Rev B

2750SXT/2850SXT WIRING DIAGRAM

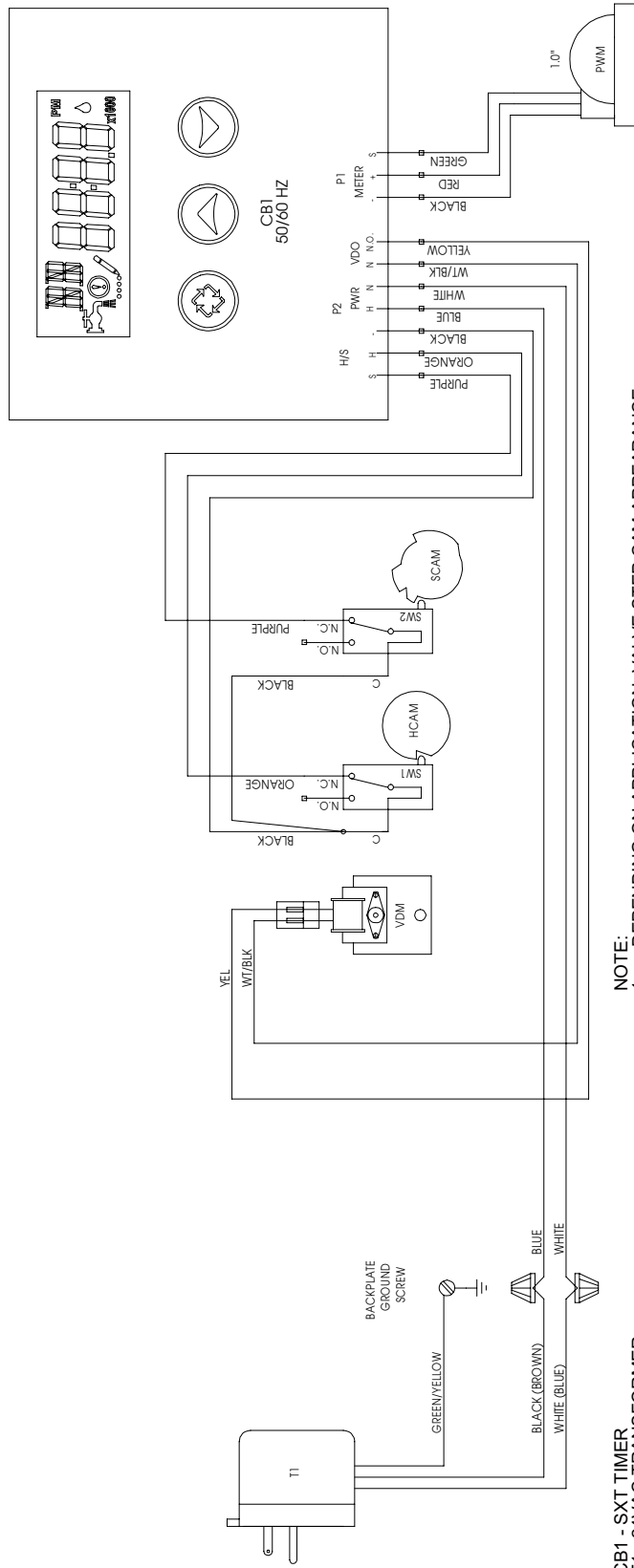

NOTE:
 1. DEPENDING ON APPLICATION, VALVE STEP CAM APPEARANCE WILL VARY.
 2. REGARDLESS OF CAM TYPE USED, WIRING TO SWITCHES SW1 AND SW2 WILL REMAIN AS SHOWN.
 3. VALVE SHOWN IN SERVICE POSITION.

- CB1 - SXT TIMER
- T1 - 24VAC TRANSFORMER
- K1 - 24VAC VALVE DRIVE RELAY
- PWM - 1.0" OR 1.5" PADDLE WHEEL FLOW METER (OPTIONAL)
- VDM - VALVE DRIVE MOTOR
- SW1 - VALVE HOMING SWITCH
- SW2 - VALVE STEP SWITCH
- HCAM - VALVE HOMING CAM
- SCAM - VALVE STEP CAM

SERVICE ASSEMBLIES

Meter

60086-50	Meter Assy, 3/4-inch, Electronic 2510/6600/6700
60613	Meter Assy, 2750 Electronic 1-inch
60613-20	Meter Assy, 2750, Electronic 1-inch BSP/Metric
60613NP	Meter Assy, 2750, Electronic 1-inch Nickel Plated
60614	Meter Assy, 2850/9500, Electronic 1-1/2 inch Meter
60614NP	Meter Assy, 2850/9500, Electronic 1-1/2 inch Meter, NP
60618	Meter Assy, Electronic, 3/4-inch
60619-20	Meter Assy, 1-1/2 inch Electronic BSP/ Metric
60626	Meter Assy, Turbine, Electronic 3/4- inch with Clips and Screws
60626-01	Meter Assy, Turbine, 3/4-inch w/Clips, Screws, Mtr/Cable
61560-01	Meter Assy, In-Line, w/1-inch NPT Plastic Connector
61560-02	Meter Assy, In-Line, w/1-inch BSP Plastic Connector
61560-07	Meter Assy, In-Line, w/1-inch NPT Brass Connector
61560-08	Meter Assy, In-Line, w/1-inch BSP Brass Connector
61560-05	Meter Assy, In-Line, w/1-inch I.D. & 1-1/4 inch O.D. Sweat Connector
61560-09	Meter Assy, In-Line, w/ 1-1/2 inch NPT Brass Connector
61560-10	Meter Assy, In-Line, w/ 1-1/2 inch BSP Brass Connector
61932-10	Meter Assy, 1 inch Stainless Steel, NPT Std
61932-11	Meter Assy, 1 inch Stainless Steel, NPT Ext
61932-10	Meter Assy, 1 inch Stainless Steel, NPT Std
61932-11	Meter Assy, 1 inch Stainless Steel, NPT Ext
61932-20	Meter Assy, 1 inch Stainless Steel, BSP Std
61932-21	Meter Assy, 1 inch Stainless Steel, BSP Ext
61933-10	Meter Assy, 1-1/2 inch Stainless Steel, NPT Std
61933-11	Meter Assy, 1-1/2 inch Stainless Steel, NPT Ext
61933-20	Meter Assy, 1-1/2 inch Stainless Steel, BSP Std,
61933-21	Meter Assy, 1-1/2 inch Stainless Steel, BSP Ext

For Fleck Product Warranties visit:
Fleck para las garantías de los productos visite: } waterpurification.pentair.com
Pour Fleck garanties produit visitez le site :



WATER QUALITY SYSTEMS

5730 NORTH GLEN PARK ROAD, MILWAUKEE, WI 53209
P: 262.238.4400 | WATERPURIFICATION.PENTAIR.COM | CUSTOMER CARE: 800.279.9404 | tech-support@pentair.com

[§]For a detailed list of where Pentair trademarks are registered, please visit waterpurification.pentair.com/brands.
Pentair trademarks and logos are owned by Pentair plc or its affiliates. Third party registered and unregistered trademarks and logos are the property of their respective owners.

42713 REV K AU16 © 2016 Pentair Residential Filtration, LLC All Rights Reserved.