

Water Specialist WS2H and WS3 Control Valve Drawings and Service Manual

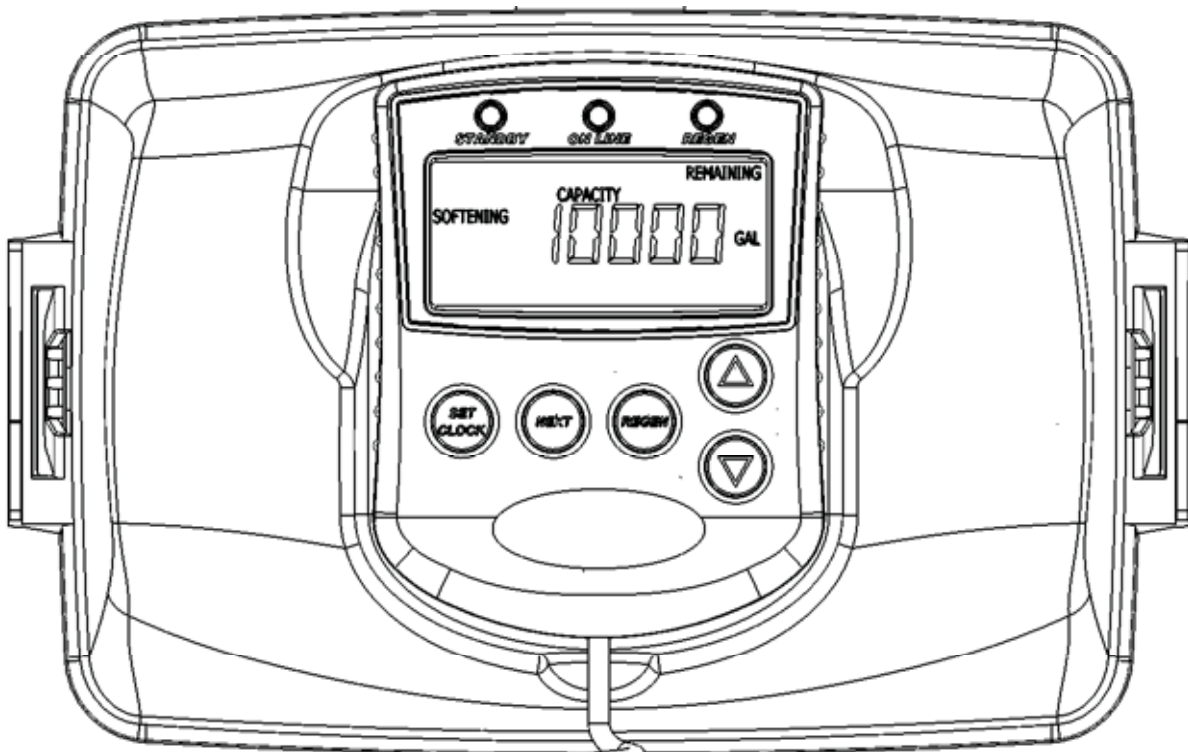

HYDROCARBONS SUCH AS KEROSENE, BENZENE, GASOLINE, ETC., MAY DAMAGE PRODUCTS THAT CONTAIN O-RINGS OR PLASTIC COMPONENTS. EXPOSURE TO SUCH HYDROCARBONS MAY CAUSE THE PRODUCTS TO LEAK. DO NOT USE THE PRODUCT(S) CONTAINED IN THIS DOCUMENT ON WATER SUPPLIES THAT CONTAIN HYDROCARBONS SUCH AS KEROSENE, BENZENE, GASOLINE, ETC.

Table of Contents

General Specifications and Pre-Installation Checklist	4
Software and Power Supply Compatibility	5
Installation Instructions	6
Installation Summary	9
WS2H Control Valve Cycle Positions	10
WS3 Control Valve Cycle Positions	13
Front Cover and Drive Assembly	16
WS2H Drive Cap Asy, Downflow Piston, Regenerant Piston, Spacer Stack Asy, Drive Back Plate and Main Body, and Meter	17
WS3 Drive Cap Asy, Downflow Piston, Regenerant Piston, Spacer Stack Asy, Drive Back Plate, Main Body	18
V3075 and V3075BSPT WS3 3" Meter Assembly	19
Brine Valve Body and Injector Components	20
Base Tank Adapters	21
V3158-04 WS2 Drain Elbow ¾" Male NPT without silencer	22
V3008-05 WS2 Drain Fitting 1" Straight Male NPT without silencer	23
V3079 and V3080 NPT and BSPT 1" and 1.5" DLFC	24
V3051 and V3051 BSPT WS2 DLFC	25
V3764 WS3 DLFC ASY and V3764BSPT	26
V3063 and V3063BSPT Motorized Alternating Valve	27
V3076 and V3076BSPT Motorized Alternating Valve	28
V3083 and V3083BSPT Motorized Alternating Valve	29
V3060 and V3060BSPT Bypass Valve	30
V3053 WS2H 2.5" Groove Lock Clamp	31
Error Codes	32
Trouble Shooting Guide	33
Standard Injector Graphs	41

Table 1
General Specifications and Pre-Installation Checklist

Minimum/Maximum Operating Pressures	20 psi (138 kPa) -125 psi (862 kPa)		
Minimum/Maximum Operating Temperatures	40°F (4°C) – 110°F (43°C)		
Power Adapter:	<u>U.S.</u>		<u>International</u>
Supply Voltage	120V AC		230V AC
Supply Frequency	60 Hz		50 Hz
Output Voltage	20V or 24V AC	see Table 2	20V or 24V AC
Output Current	800 mA		800 mA
No user serviceable parts are on the PC board, the motor, or the Power adapter. The means of disconnection from the main power supply is by unplugging the Power adapter from the wall.			
Service flow rate	WS2H Valve: 125 gpm (473 lpm, 28.4 m ³ /h) @ 15 psig (103 kPa) drop WS3 Valve: 250 gpm (946 lpm, 56.8 m ³ /h) @ 15 psig (103 kPa) drop		
Backwash flow rate	WS2H Valve: 125 gpm (473 lpm, 28.4 m ³ /h) @ 25 psig (172 kPa) drop WS3 Valve: 220 gpm (833 lpm, 50.0 m ³ /h) @ 25 psig (172 kPa) drop		
CV Service	WS2H Valve: 32.3 WS3 Valve: 64.6		
CV Backwash	WS2H Valve: 25.0 WS3 Valve: 44.0		
Meter:	WS2H Valve: Internal Meter		WS3 Valve: Optional External Meter
Accuracy	± 5 %		± 5 %
Flow Range	1.5 – 125 gpm (5.7 – 473 lpm)		3.5 – 350 gpm (13.3 – 1325 lpm)
Regenerant Refill Rate	WS2H and WS3 Valves: Variable - Shipped from Factory with 2.2 gpm (8.33 lpm)		
Injectors	WS2H & WS3 Valves: See Injector Graphs V3010-2A through 2H		
Brine Line Adapters Included	1" Male NPT Elbow & ¾" x 1" Solvent Weld Elbow		
Inlet, Outlet and Drain Line Openings	WS2H Valve: 2" Female NPT or BSPT or 2.5" Groove Lock WS3 Valve: 3" Female NPT or BSPT, No Groove Lock		
Distributor Tube Opening:	Female NPT Inlet & Outlet		Female BSPT Inlet & Outlet
WS2H Valve	2.375" OD (2.0" NPS)		63 mm OD
WS3 Valve	3.5" OD (3" NPS)		90 mm OD
Tank Connection:	4"-8UN, 6" Flange, Side Mount (2" Female NPT or BSPT or 2.5" Groove Lock)		
WS2H Valve	6" Flange or Side Mount (3" Female NPT or BSPT)		
WS3 Valve			
Shipping Weight	WS2H Valve with Meter: 50 lbs (22.7 kg) WS3 Valve: 57 lbs (25.9 kg) Meter Sold Separately		
PC Board Memory	Nonvolatile EEPROM (electrically erasable programmable read only memory)		
Compatible with the following typical concentrations of regenerants/chemicals	Sodium chloride, potassium chloride, potassium permanganate, sodium bisulfite, chlorine and chloramines		

Table 2
Software and Power Supply Compatibility

Software Version		Power Supply	
V3242-01BOARD Main Board ¹	V3243-01BOARD System Board	Output Voltage	Part # and Description
114.10	1.03	24 VAC	V3461 ² WS2H/3 AC ADAPTER V3461EU WS2H/3 AC ADAPTER EU V3461UK WS2H/3 AC ADAPTER UK
114.11			
115.17	1.07 or 1.08		
115.25			
200.01			
215.02	1.11 or 1.13		
215.03			
215.04			
215.10	1.11 or 1.13	24 VAC	V3461 ² WS2H/3 AC ADAPTER V3461EU WS2H/3 AC ADAPTER EU V3461UK WS2H/3 AC ADAPTER UK
		20 VAC ³	V3461-01 WS2H/3 AC ADAPTER 20V V3461EU-01 WS2H/3 AC ADAPTER EU 20V V3461UK-01 WS2H/3 AC ADAPTER UK 20V

¹ It is recommended to maintain one version throughout a system.

² Replacement V3461 power supplies have screw terminals and are shipped less a cord. Use cord from existing power supply to connect to the screw terminals.

³ V3461EU-01 and V3461UK-01 will not be available for sale until August 2010.

Installation:

WS2H CONTROL VALVE TOP VIEW

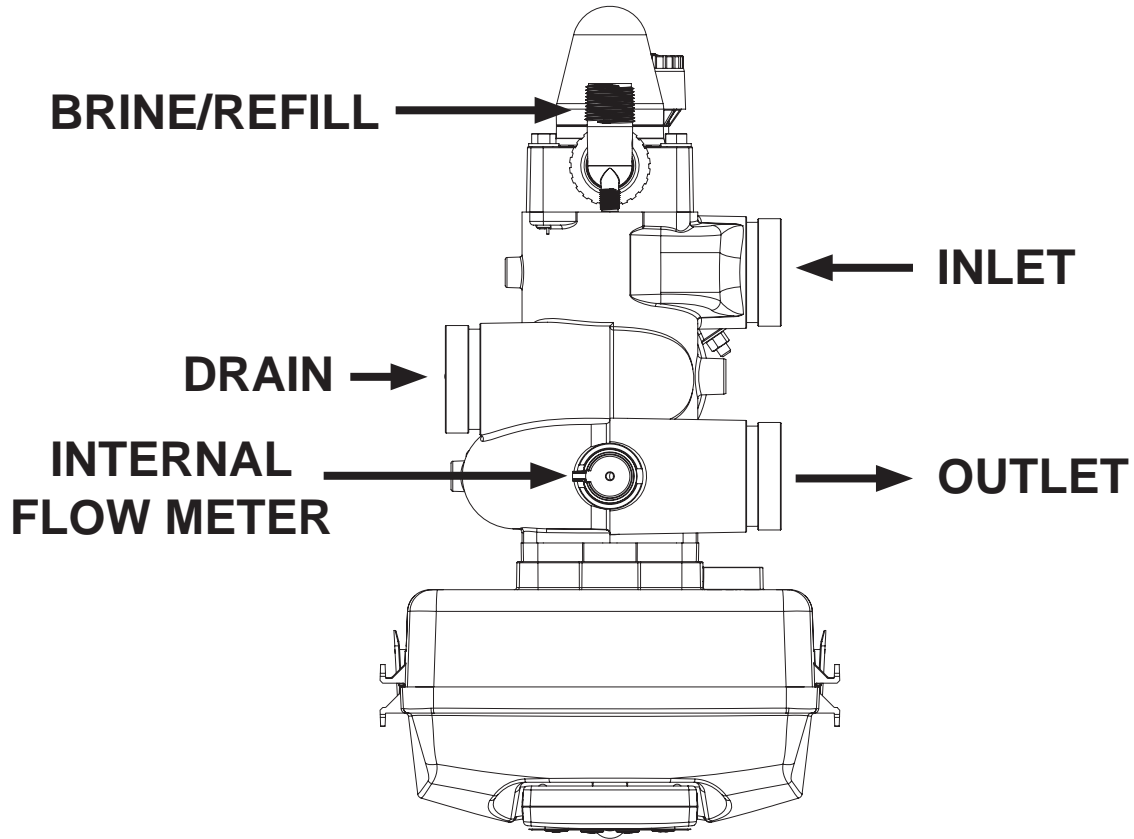

WS3 CONTROL VALVE TOP VIEW

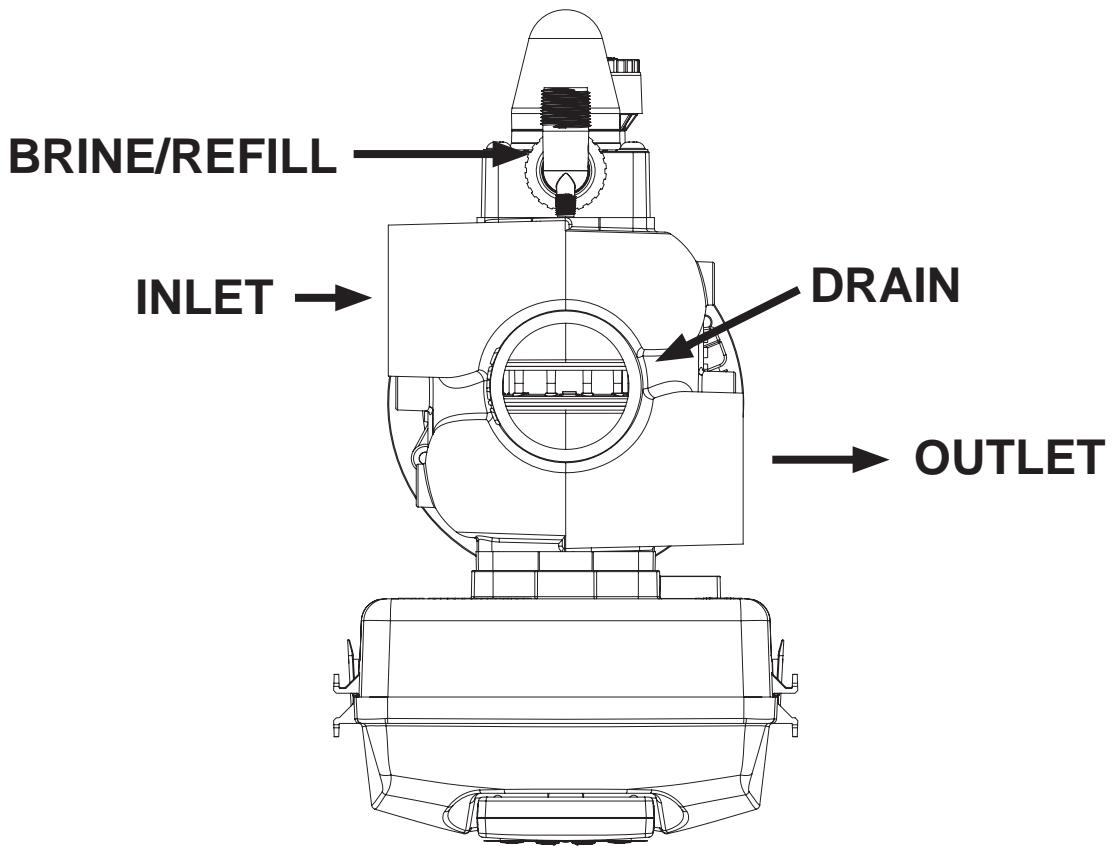

DISTRIBUTOR PIPE HEIGHT:

Recommended distributor pipe height for top mounted WS2H Control valves is 2 ¼” – 2 ½” above the top of tank for fiberglass tanks. Please verify distributor pipe and pilot o-ring engagement and make proper allowances for tank expansion.

Recommended distributor pipe height for top mounted WS3 Control valves is 2 ½” – 2 ¾” above the top of tank for fiberglass tanks. Please verify distributor pipe and pilot o-ring engagement and make proper allowances for tank expansion.

GENERAL INSTALLATION & SERVICE WARNINGS

The control valve and fittings are not designed to support the weight of the system or the plumbing.

Do not use Vaseline, oils, other hydrocarbon lubricants or spray silicone anywhere. A silicone lubricant may be used on black o-rings but is not necessary.

HYDROCARBONS SUCH AS KEROSENE, BENZENE, GASOLINE, ETC., MAY DAMAGE PRODUCTS THAT CONTAIN O-RINGS OR PLASTIC COMPONENTS. EXPOSURE TO SUCH HYDROCARBONS MAY CAUSE THE PRODUCTS TO LEAK. DO NOT USE THE PRODUCT(S) CONTAINED IN THIS DOCUMENT ON WATER SUPPLIES THAT CONTAIN HYDROCARBONS SUCH AS KEROSENE, BENZENE, GASOLINE, ETC.

THIS WATER METER SHOULD NOT BE USED AS THE PRIMARY MONITORING DEVICE FOR CRITICAL OR HEALTH EFFECT APPLICATIONS

Do not use pipe dope or other sealants on threads. Teflon tape is recommended to be used on all threads.

Use of pipe dope may break down the plastics in the control valve.

SITE REQUIREMENTS:

- The plug-in Power adapter is for dry locations only
- The tanks should be on a firm, level surface
- Electrical: Use an uninterrupted outlet installed within 15 feet (4.57 meters) of the water conditioner.

All plumbing should be done in accordance with local codes.

1. Locate the water conditioner so the distance between the drain and the water conditioner is as short as possible.
2. Regenerant tanks that must be refilled should be located where they are easily accessible. It is recommended a safety brine valve be used.
3. Do not install any water conditioner with less than 10 feet of piping between its outlet and the inlet of a water heater.
4. Do not locate unit where it or its connections (including the drain and overflow lines) will ever be subjected to room temperatures under 40° F (4° C).
5. The use of resin cleaners in a non-vented enclosure is not recommended.

6. INLET/OUTLET PLUMBING: Connect to a supply line downstream of outdoor spigots. Install inlet and outlet shutoff valves for the control valve; see top view drawings for control valve inlet and outlet locations. Installation of a three valve bypass is recommended. If using plastic fittings ground the water conditioner per local electric codes. If an external water meter is used, install the water meter on the outlet side of the control valve. It is recommended that the meter assembly be installed horizontally or in a downflow vertical position to reduce turbine bearing wear. The turbine assembly may be orientated in any direction. Remove the cover and drive bracket and thread the water meter cord through the hole in the back plate. Reinstall the drive bracket. Weave the cord through the strain relief on the backplate and connect the end to the three prong connector labeled FLOW on the printed circuit board. Re-install the cover.

7. Drain: Verify that the drain can handle the backwash rate of the water conditioner. Correctly size the drain line and install an appropriately sized drain line flow control. For WS2H and WS3 valves a drain line flow control are NOT supplied with a valve. For WS2H valves the drain outlet is 2" Female NPT or BSPT threads or 2.5" groove lock connection. For WS3 valves the drain port is 3" Female NPT or BSPT, no groove lock connection. If using copper, solder joints near the drain must be done prior to connecting the drain line flow control fitting. Leave at least 6" (152.4 mm) between the drain line flow control fitting and solder joints to prevent heat from damaging the flow control. Avoid elevating the drain line above the control valve where possible. Discharge the drain line through an air gap to a receptacle in accordance with local plumbing codes.

IMPORTANT: Never insert a drain line directly into a drain, sewer line, or trap. Always allow an air gap between the drain line and the receptacle to prevent back siphonage.

8. Regeneration: If the control valve is to be used to regenerate the water conditioner with brine (saturated salt solution) or other regenerants. The WS2H and WS3 control valves regenerant port has a 1" 90° Male NPT threaded outlet connection that swivels 360°. To ensure acceptable operation of the injectors use 1" pipe to connect to the brine tank. Smaller drain line flow controls may result in the injector performance not matching the injector graphs. Use an adequately size drain line flow control to ensure proper brine draw. See Table 3 for injector order number and size for tank diameter. An overflow drain line from the regenerant tank that discharges into an acceptable drain is recommended, as a regenerant overflow could damage furnishings or the building structure. Connect a line to the overflow fitting on the regenerant tank. If an overflow fitting is not already installed on the regenerant tank, install one. Do not elevate the overflow drain line. Discharge the overflow drain line through an air gap to a receptacle in accordance with local plumbing codes.

Table 3
WS2H and WS3 Valve Injector Order Information

Injector Order Number	Typical Tank Diameter⁴
V3010-2A	18"
V3010-2B	21"
V3010-2C	24"
V3010-2D	30"
V3010-2E	36"
V3010-2F	42"
V3010-2G	48"
V3010-2H	63"

All injector graphs are at the end of this manual for total, slow rinse and draw flow rates.

⁴Actual injector size used may vary depending on the design and application of the system. Injectors in table are sized for a typical downflow softener using standard mesh synthetic cation exchange media regenerating with sodium chloride.

9. Power Adapter: If a Power Adapter is already connected to the control valve, plug the Power Adapter into an uninterrupted outlet. If the Power Adapter cord has not yet been connected to the control valve, remove the control valve cover and the drive bracket and thread Power Adapter cord through the hole in the back plate. Reinstall the drive bracket. Weave the cord through the strain relief on the backplate and connect the end to the four pin connector on the printed circuit board labeled POWER. Reinstall the cover. Plug the Power Adapter into an uninterrupted outlet.

10. Program the control valve: It is very important to program the control valve for the type of system (e.g. water softener or filter) and the end use application. Check the program used prior to testing the system.

Installation Summary

Installation Date: _____

Installation Location: _____

Installer(s): _____

Phone Number: _____

Application Type: (Softener)_____ Other: _____

Water Source: _____

Water Test Results:

Hardness:_____ **Iron:** _____ **pH:**_____

Other: _____

Misc:

Service Flow Rates: min. _____ max. _____

Tank Size: Diameter _____ Height: _____

Resin or Media Volume: _____

Resin or Media Type: _____

Capacity: _____

Salt or Fill Setting per Regeneration: _____

Brine Tank Size: _____

Control Valve Configuration:

Valve Type: _____

Valve Part Number: _____

Valve Serial Number: _____

Regenerant Refill Control: _____ gpm/lpm

Injector Size: _____

Drain Line Flow Control: _____ gpm/lpm

WS2H Control Valve Cycle Positions

SERVICE

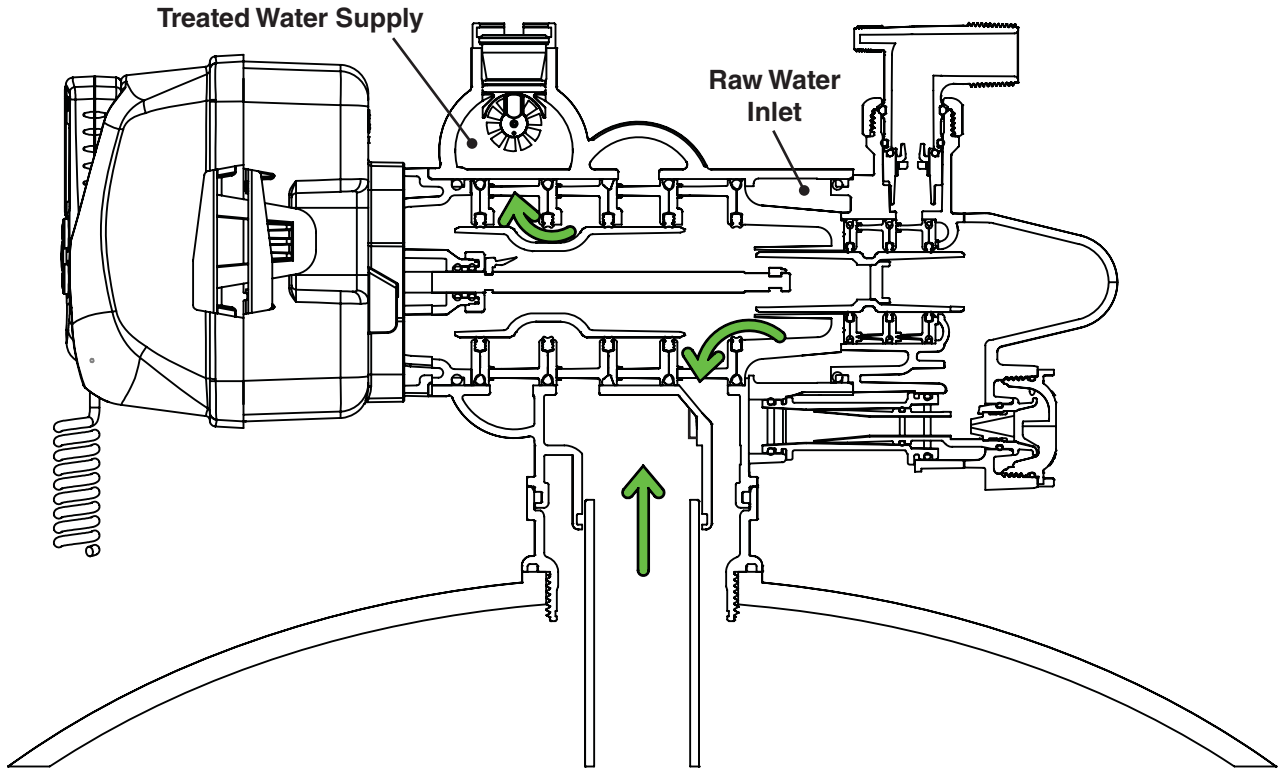

BACKWASH

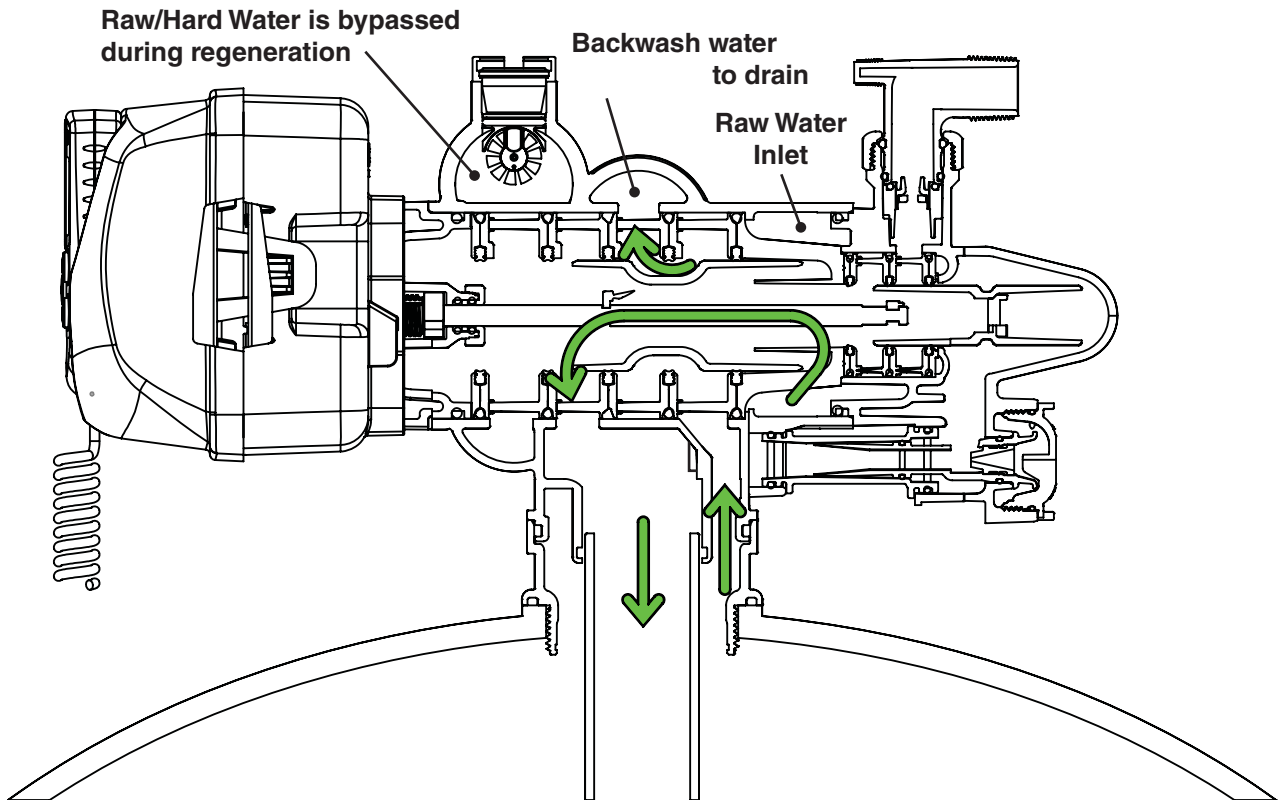

DRAW

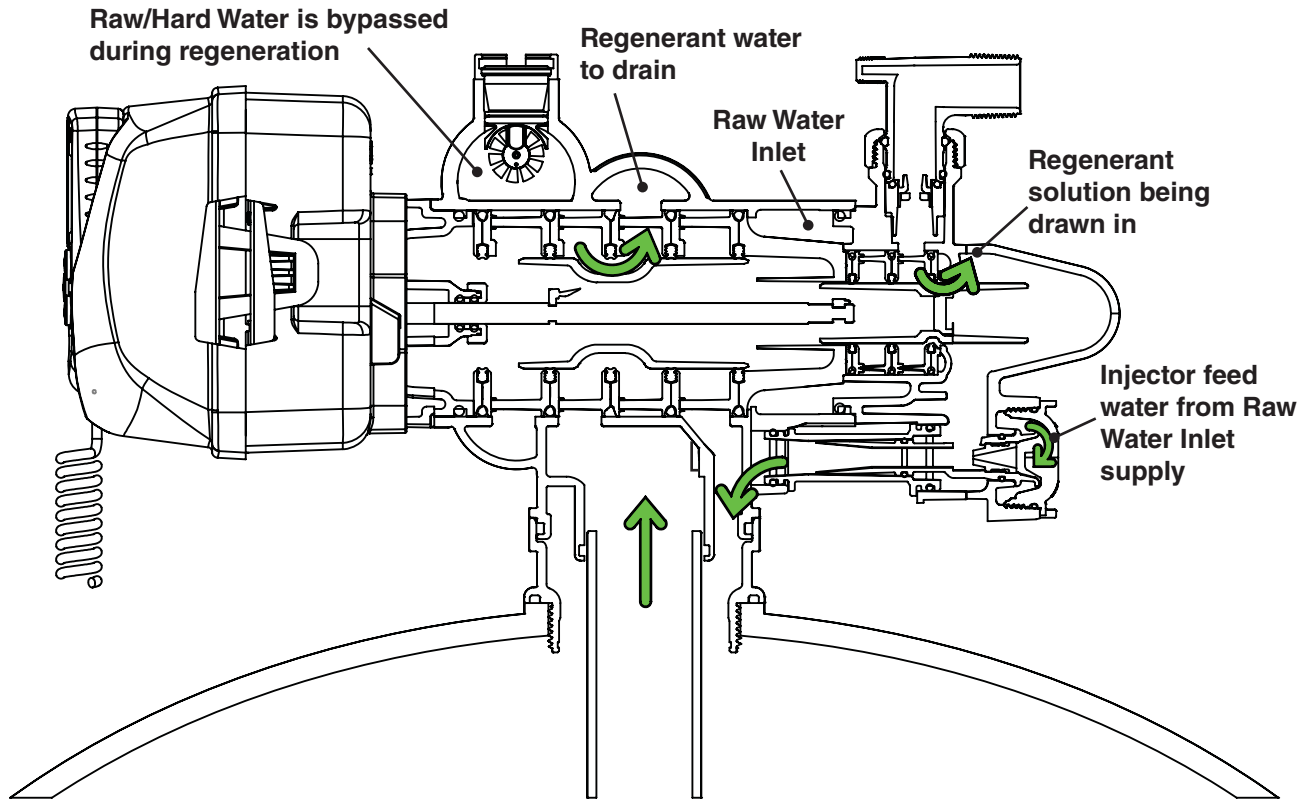

SLOW RINSE

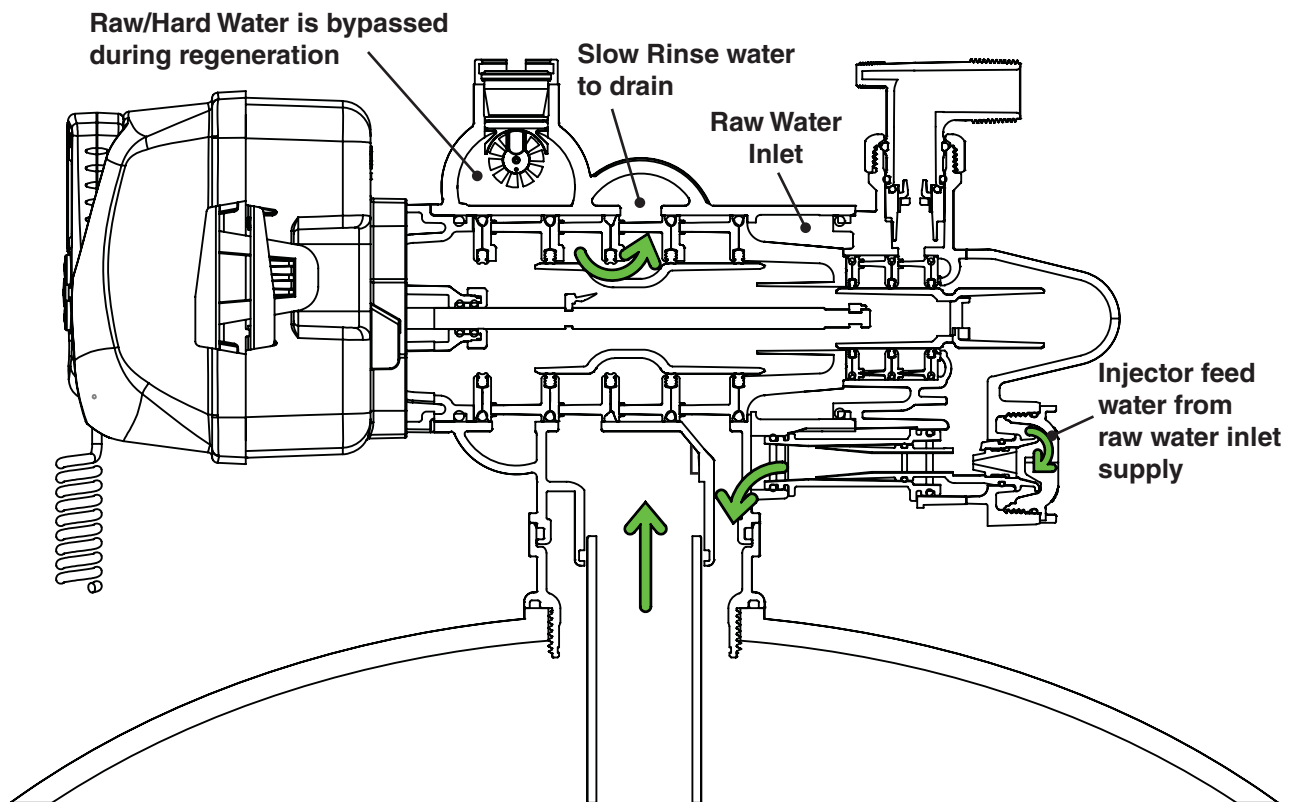

RINSE

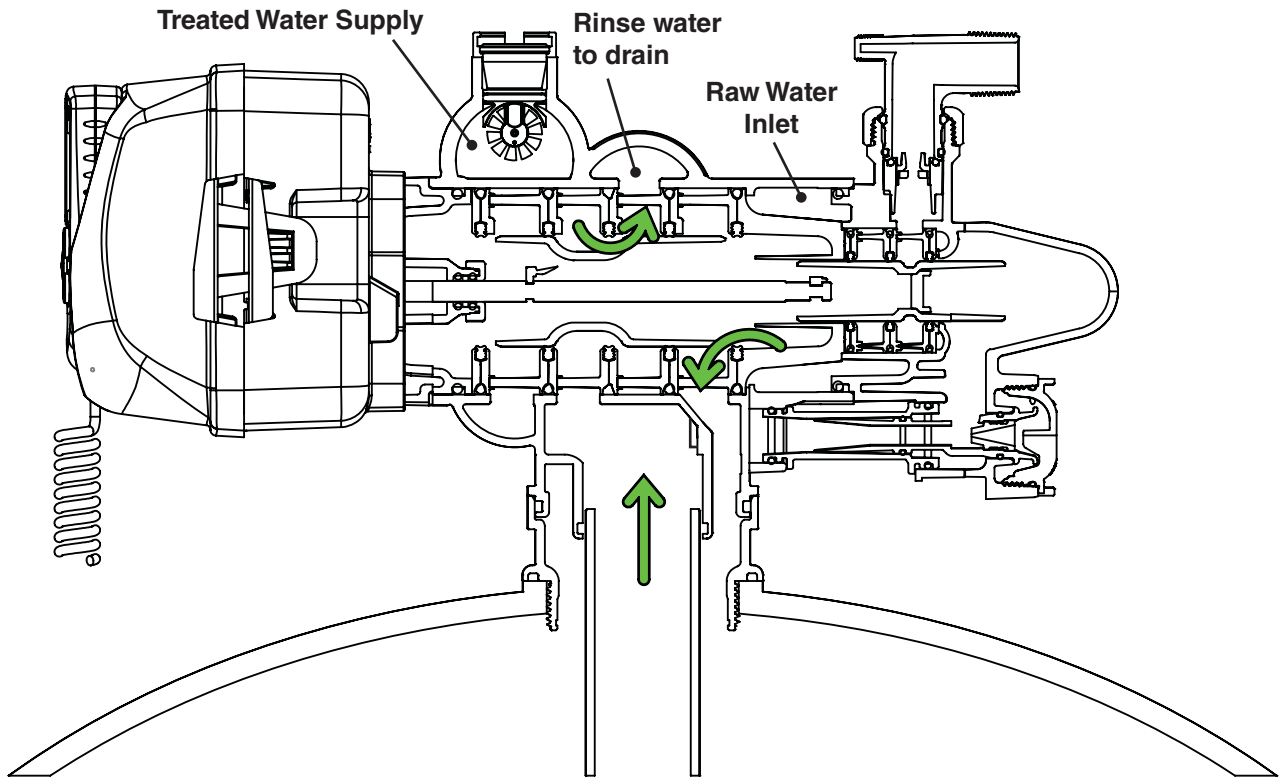

SOFT WATER REFILL

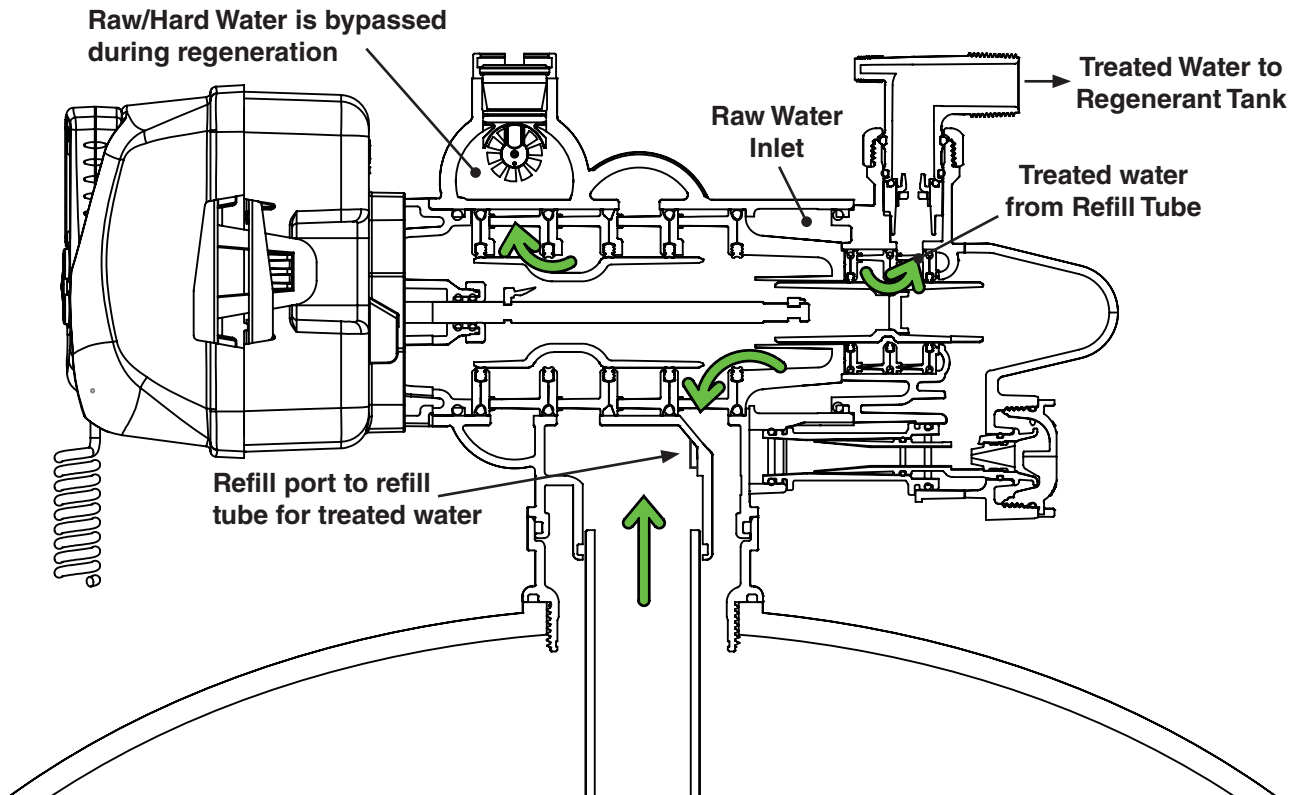

WS3 Control Valve Cycle Positions

SERVICE

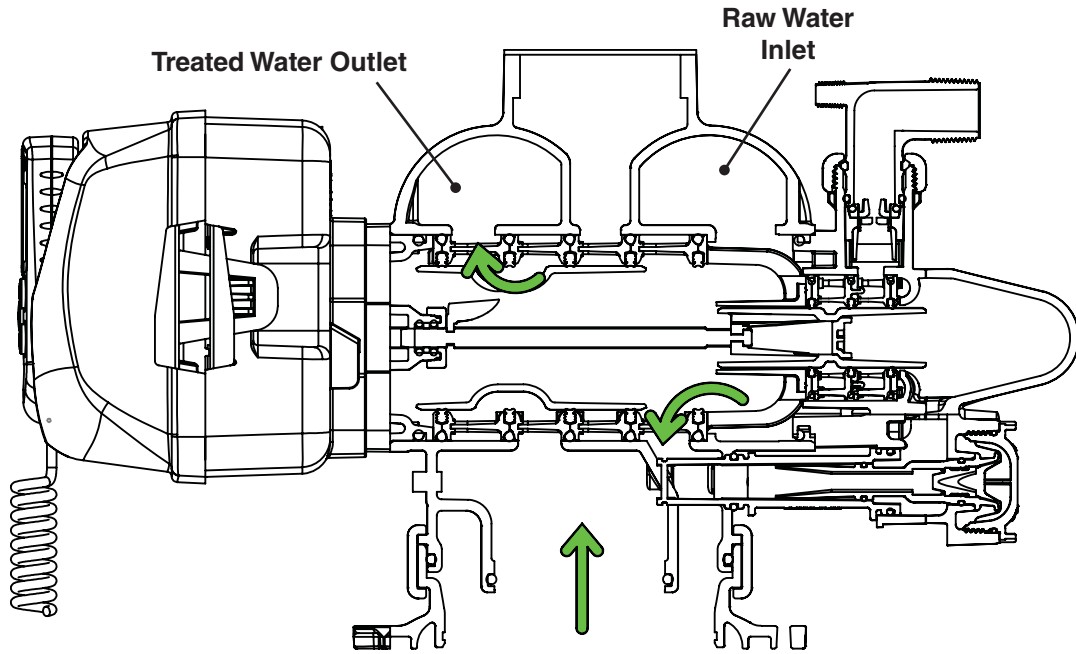

BACKWASH

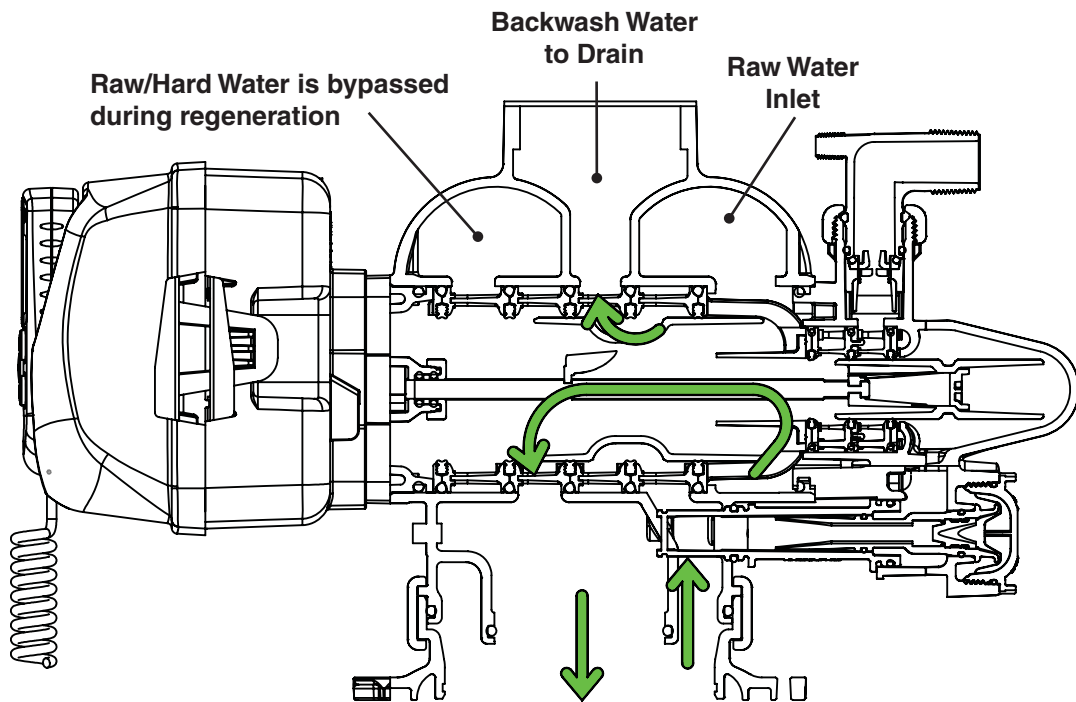

DRAW

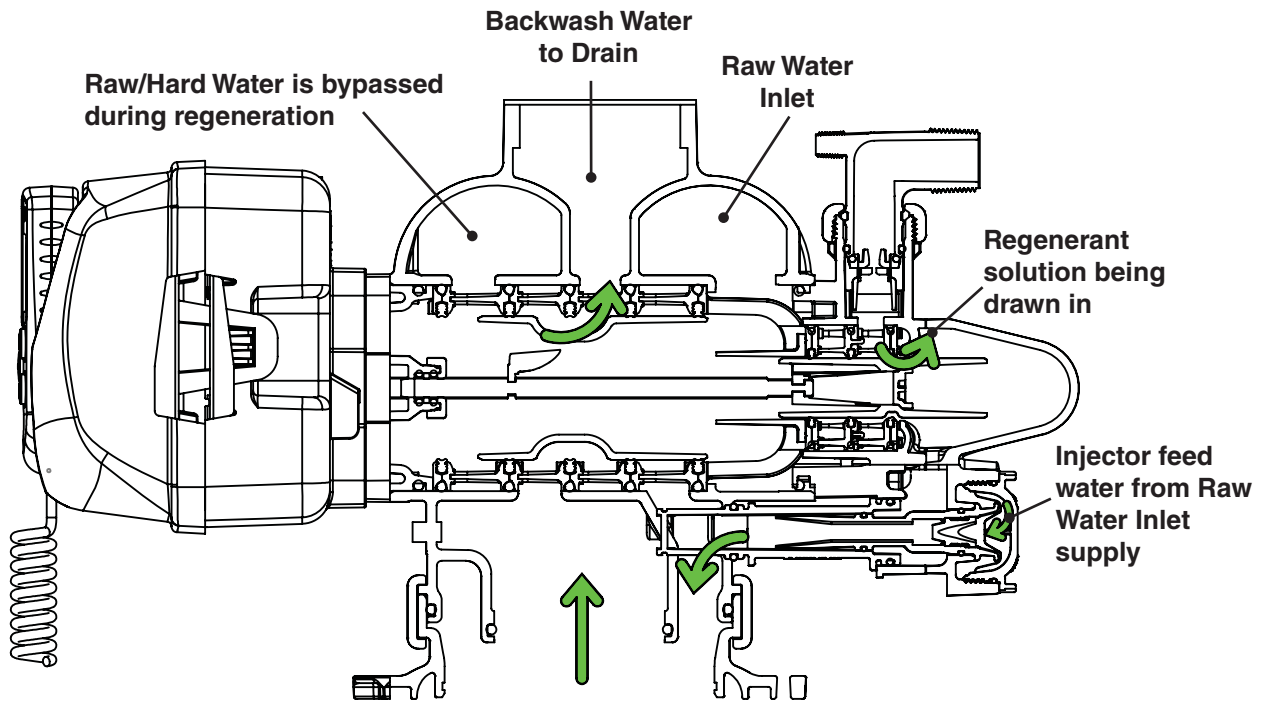

SLOW RINSE

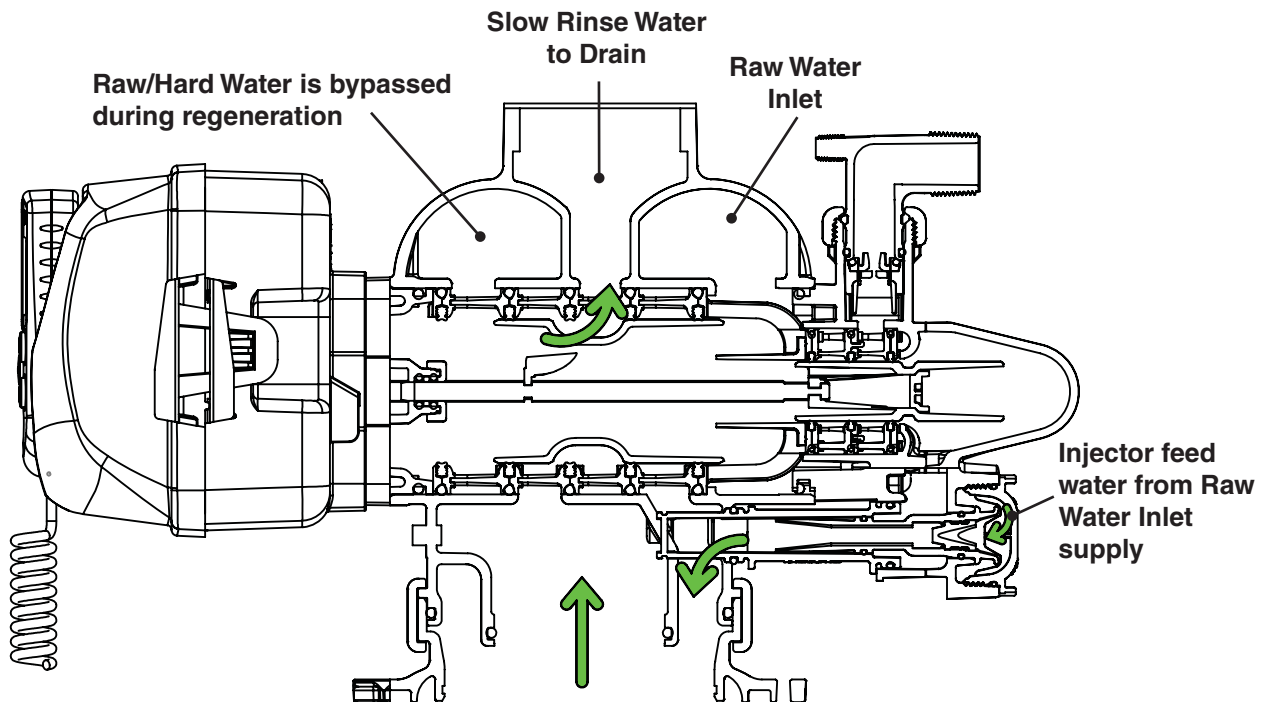

RINSE

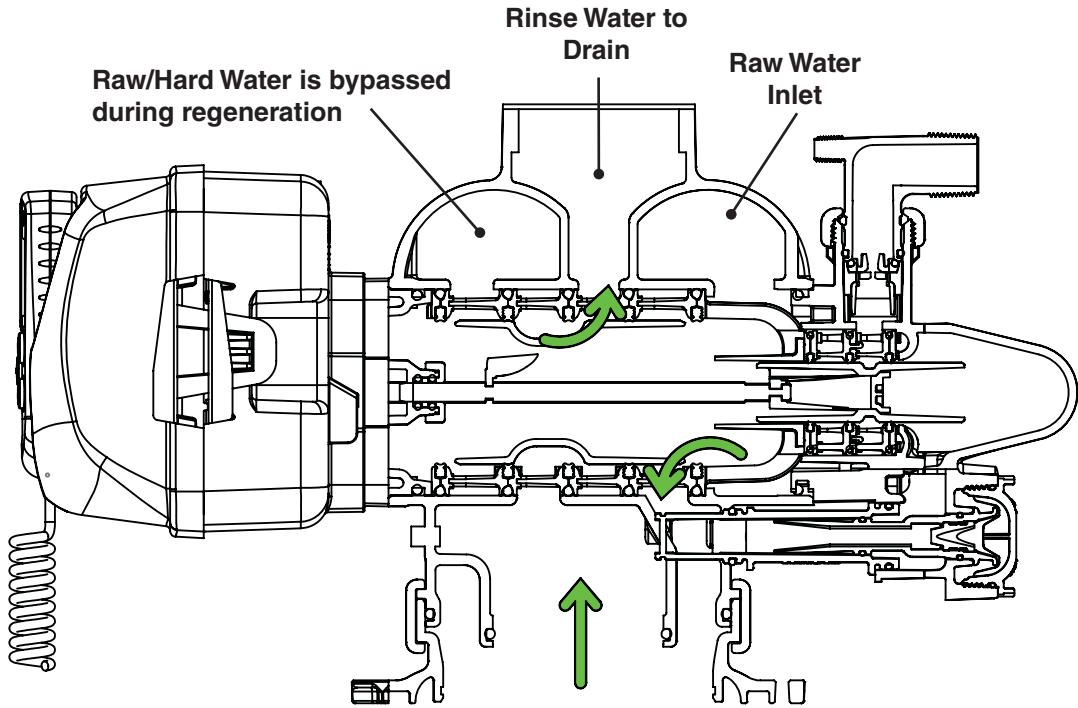

SOFT WATER REFILL

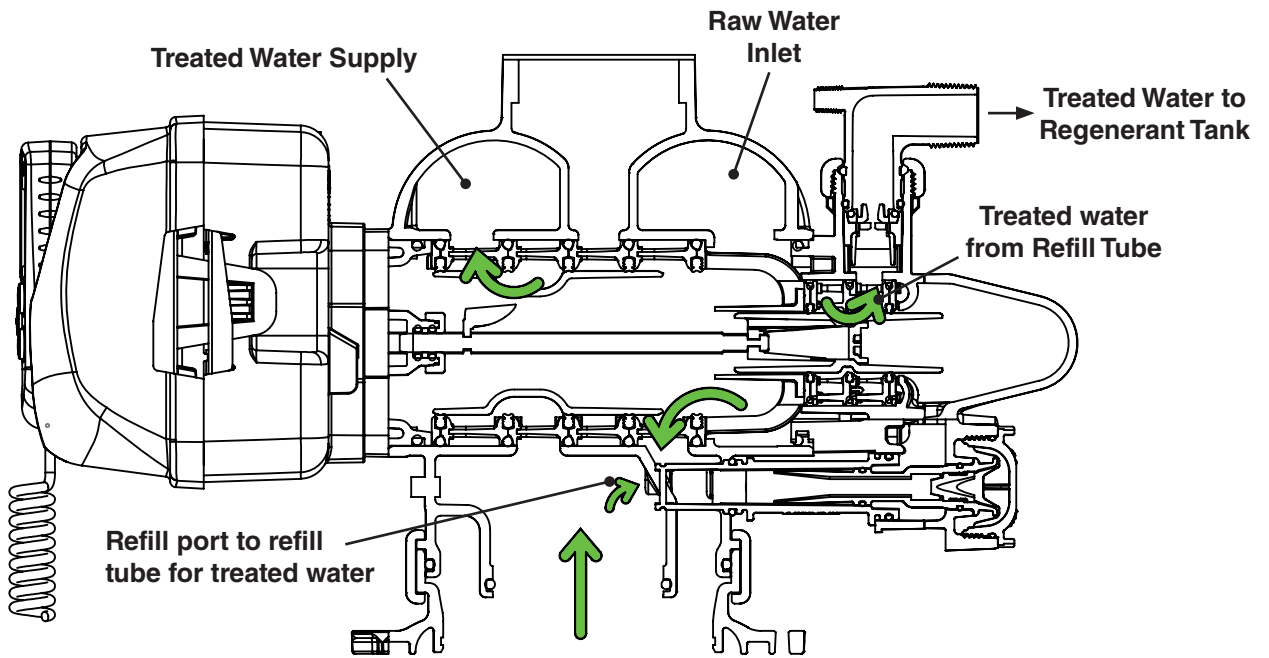

Front Cover and Drive Assembly

Drawing No.	Order No.	Description	Quantity
1	V3068	WS2H/3 POD FRNT-BK COVERS	1
1a	V3082	WS2H/3 POD ASY COMPLETE W/BOARD*	Optional
2	V3241-01 BOARD	WS2H/3 PC BOARD DISPLAY	1
3	V3248	WS2H/3 CABLE DISPLAY POD	1
4	V3242-01BOARD	WS2H/3 PC BOARD VALVE	1
5	V3224-01R	WS2H/3 COVER ASY PLATINUM	1
6	V3107-01	WS1 MOTOR ASY	1
7	V3226-01	WS2H/3 DRIVE BRACKET ASY	1
8	V3110	WS1 DRIVE GEAR 12X36	3
9	V3109	WS1 DRIVE GEAR COVER	1
Not Shown	V3461	WS2H/3 AC ADAPTER (shipped less cord)	1 See Table 2 Software and Power Supply Compatibility for option selection
	V3461EU	WS2H/3 AC ADAPTER EU	
	V3461UK	WS2H/3 AC ADAPTER UK	
	V3461-01	WS2H/3 AC ADAPTER 20VAC	
	V3461EU-01	WS2H/3 AC ADAPTER EU 20VAC	
	V3461UK-01	WS2H/3 AC ADAPTER UK 20VAC	
10	V3243-01BOARD	WS2H/3 PC BOARD SYSTEM	Optional
Not Shown	V3475-12	WS2H/3 SYS CONNECT CORD 12 FT RED	Optional
Not Shown	V3475-24	WS2H/3 SYS CONNECT CORD 24 FT BL	Optional
Not Shown	V3475-36	WS2H/3 SYS CONNECT CORD 36 FT YEL	Optional

*Contains items 1,2 & 3 Pod Assembly, PC Board and Cable

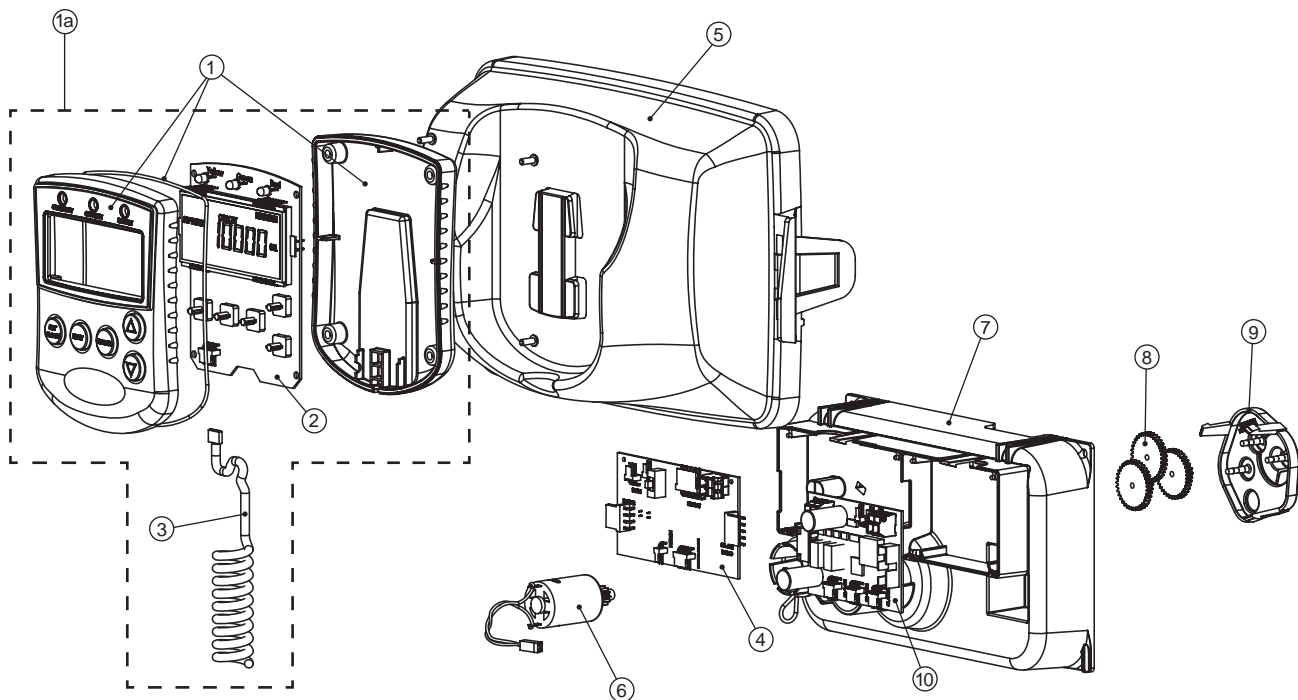

WS2H Drive Cap Assembly, Downflow Piston, Regenerant Piston, Spacer Stack Assembly, Drive Back Plate, Main Body and Meter

Drawing No.	Order No.	Description	Quantity
1	V3275	WS2H/3 SCREW BTNSKT HD SS3/8-16X2-1/4 (7/32" hex allen wrench required)	4
2	V3291	WS2H/3 WASHER SS 3/8	4
3	V3225	WS2H/3 BACK PLATE	1
4	V3066	WS2H DRIVE ASY	1
5	V3289	O-RING 344	1
6	V3204-01	WS2H PISTON	1
7	V3238-01***	WS2H/3 BRINE PISTON	1
8	V3065	WS2H STACK ASY	1
Not Shown	V3468	WS2H/3 PLUG 1/4 HEX NPT (included when ordering V3201-03)	2
	V3465	WS2H/3 PLUG 1/4 HEX BSPT (included when ordering V3201BSPT-03)	
9	V3201-03	WS2H BODY W/V3468 PLUG	1
	V3201BSPT-03	WS2H BSPT BODY W/V3465 PLUG	
10	V3632*	WS1.5/2/3 METER RETAINING CLIP	1
11	V3003-02	WS1.5/2H METER COMMERCIAL ASY	1
12	V3118-03	WS1.5/2 TURBINE ASY	1
13	V3105	O-RING 215	1
14	V3501	WS1.5/2 TURBINE CLIP	1
15	V3279	O-RING 346	1
16	V3280	O-RING 332 FOR VALVE BODIES WITH NPT THREADS	1
	V3452	O-RING 230 FOR VALVE BODIES WITH BSPT THREADS	
17	V3054**	WS2H 4 IN BASE CLAMP ASY	1
18	V3276	WS2H/3 BOLT HEX SS 5/16-18X1-3/4	1
19	V3269	WS2H/3 NUT 5/16-18 SS HEX	1
Not Shown	D1300-01	TOP BAFFLE DFSR CLACK 2/63MM	1

* In 2008 a modification was made to Meter Housings to use V3632 WS1.5/2/3 Meter Retaining Clip. Do not use V3632 on old style housings which have holes through the castings to accept the U-shaped V3223 WS2 Meter Clip.

**V3054 WS2 4 IN BASE CLAMP ASY includes a V3276 WS2 BOLT HEX SS 5/16-18X1-3/4 and V3269 WS2 NUT 5/16-18 SS HEX.

***V3238-01 Brine Piston is used for Backwash Only valves.

THIS WATER METER SHOULD NOT BE USED AS THE PRIMARY MONITORING DEVICE FOR CRITICAL OR HEALTH EFFECT APPLICATIONS.

Service or replace the turbine by:

1. Turn the bypass for the system off and relieve the pressure on the system.
2. Press downward on the remote meter assembly to relieve tension on the retaining clip V3632 (or the U-shaped V3223 WS2 Meter Clip). Remove the clip and take the meter assembly out of the housing.
3. Remove the bend from the two exposed tips of the retaining clip V3501 and remove clip.
4. Service or replace the V3118-03 WS15/2 Turbine Assembly and place it back in the turbine shaft.
5. Insert the V3501 WS15/2 Turbine Clip and re-bend the exposed ends of the clip. The V3118-03 turbine has a groove to line up with the V3501 WS15/2 Turbine Clip.
6. Insert meter assembly back into the meter housing.
7. Re-install the meter retaining clip V3632 as shown below (or the U-shaped V3223 WS2 Meter Clip).
8. Open the bypass for the system slowly to bring back into service and check to be sure you have no water leaks.

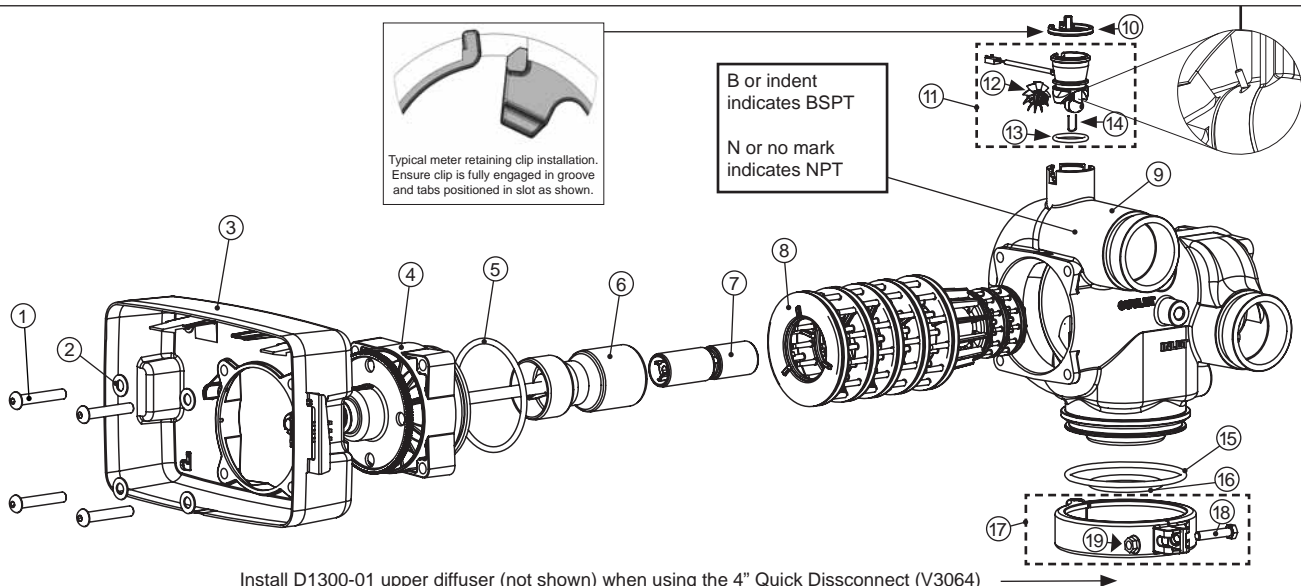

Install D1300-01 upper diffuser (not shown) when using the 4" Quick Disconnect (V3064)

**WS3 Drive Cap Assembly, Downflow Piston, Regenerant Piston, Spacer Stack Assembly,
Drive Back Plate and Main Body**

Drawing No.	Order No.	Description	Quantity
1	V3274	WS2H/3 SCREW BTNSKT HD SS3/8-16X2 (7/32" hex allen wrench required)	4
2	V3291	WS2H/3 WASHER SS 3/8	4
3	V3225	WS2H/3 BACK PLATE	1
4	V3093	WS3 DRIVE ASY	1
5	V3289	O-RING 344	1
6	V3666-01	WS3 PISTON	1
7	V3238-01**	WS2H/3 BRINE PISTON	1
8	V3092	WS3 STACK ASY	1
Not Shown	V3468	WS2H/3 PLUG 1/4 HEX NPT (included when ordering V3667-03)	2
	V3465	WS2H/3 PLUG 1/4 HEX BSPT (included when ordering V3667BSPT-03)	
9	V3667-03	WS3 BODY W/V3468 PLUG	1
	V3667BSPT-03	WS3 BSPT BODY W/V3465 PLUG	
10	V3763	O-RING 361	1
11	V3762	O-RING 341 FOR VALVE BODIES WITH NPT OR BSPT THREADS	1
12	V3091*	WS3 BASE CLAMP ASY	1
13	V3276	WS2H/3 BOLT HEX SS 5/16-18X1-3/4	1
14	V3269	WS2H/3 NUT 5/16-18 SS HEX	1
Not Shown	V3672	TOP BAFFLE DFSR CLACK 3/90MM	1

*V3091 WS3 BASE CLAMP ASY includes a V3276 WS2H/3 BOLT HEX SS 5/16-18X1-3/4 and V3269 WS2H/3 NUT 5/16-18 SS HEX.

**V3238-01 Brine Piston is used for Backwash Only valves.

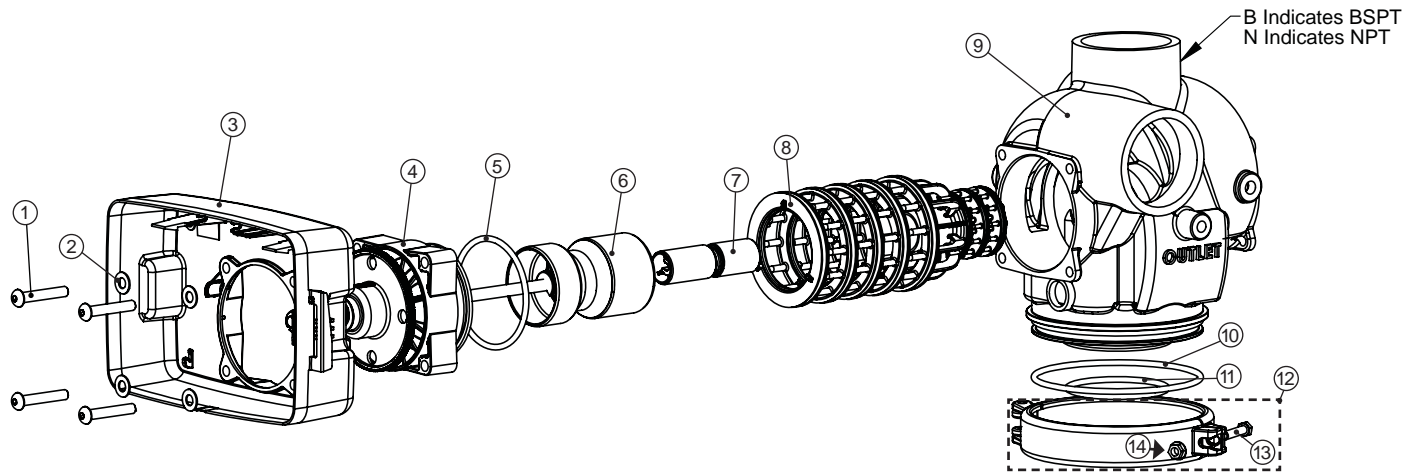

Install V3672 upper diffuser (not shown) when using the 6" Flange Base (V3090) →

V3095 WS3 METER NPT MXF ASSEMBLY, V3095BSPT WS3 METER BSPT MXF ASSEMBLY, V3095-15 WS3 METER ASY NPT MXF 15FT AND V3095BSPT-15 WS3 METER BSPT MXF 15FT

Service or replace the turbine by:

1. Turn the bypass for the system off and relieve the pressure on the system.
2. Press downward on the remote meter assembly to relieve tension on the retaining clip V3632. Remove the clip and take the meter assembly out of the housing.
3. Remove the bend from the two exposed tips of the retaining clip V3501 and remove clip.
4. Service or replace the V3118-03 WS15/2 Turbine Assembly and place it back in the turbine shaft.
5. Insert the V3501 WS15/2 Turbine Clip and re-bend the exposed ends of the clip. The V3118-03 turbine has a groove to line up with the V3501 WS15/2 Turbine Clip.
6. Insert meter assembly back into the meter housing.
7. Re-install the meter retaining clip V3632 as shown above.
8. Open the bypass for the system slowly to bring back into service and check to be sure you have no water leaks.

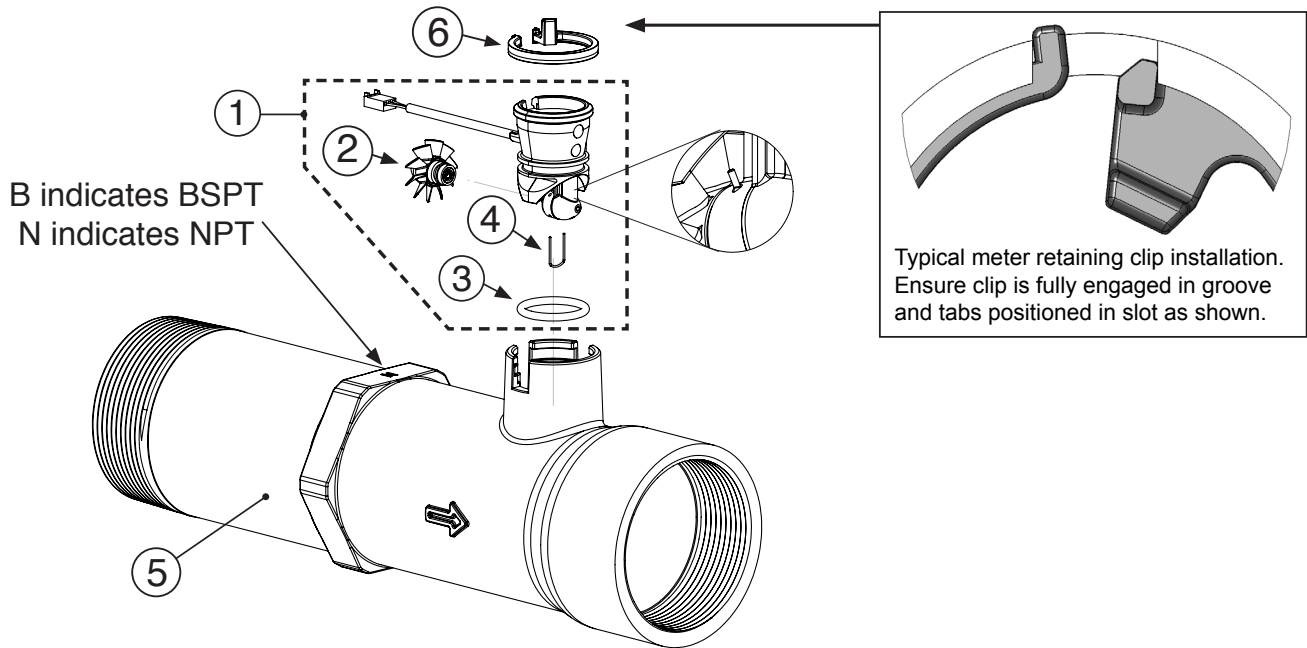

Drawing No.	Order No.	Description	V3095	V3095BSPT	V3095-15	V3095BSPT-15
1	V3003-02	WS1.5/2L/2H METER COMMERCIAL ASY (includes V3118-03, V3105 & V3501)	1	1		
	V3221	WS REMOTE METER ASY 15 FT CORD (includes V3118-03, V3105 & V3501)			1	1
2	V3118-03	WS15/2 TURBINE ASY	1	1	1	1
3	V3105	O-RING 215	1	1	1	1
4	V3501	WS15/2 TURBINE CLIP	1	1	1	1
5	V3844-01	WS3 METER NPT MxF HOUSING	1		1	
	V3844BSPT-01	WS3 METER BSPT MxF HOUSING		1		1
6	V3632	WS1.5/2/3 METER RETAINING CLIP	1	1	1	1
Not shown	V3602	WS3 FLOW STRAIGHTENER (located inside meter housing)	1	1	1	1

**V3095 WS3 METER NPT MXF ASSEMBLY, V3095BSPT WS3 METER BSPT MXF ASSEMBLY,
V3095-15 WS3 METER ASY NPT MXF 15FT AND V3095BSPT-15 WS3 METER BSPT MXF 15FT**

Installation:

- For V3095 and V3095-15 WS3 METER ASY, use 3" NPT pipe and fittings.
- For V3095BSPT and V3095BSPT-15 WS3 METER ASY, use 3" BSPT pipe and fittings.

WHEN INSTALLING THE METER, MAKE SURE THE ARROW ON THE METER BODY IS GOING THE SAME DIRECTION AS THE WATER FLOW. THE METER CAN BE INSTALLED IN HORIZONTAL OR VERTICAL APPLICATIONS.

HYDROCARBONS SUCH AS KEROSENE, BENZENE, GASOLINE, ETC., MAY DAMAGE PRODUCTS THAT CONTAIN O-RINGS OR PLASTIC COMPONENTS. EXPOSURE TO SUCH HYDROCARBONS MAY CAUSE THE PRODUCTS TO LEAK. DO NOT USE THE PRODUCT(S) CONTAINED IN THIS DOCUMENT ON WATER SUPPLIES THAT CONTAIN HYDROCARBONS SUCH AS KEROSENE, BENZENE, GASOLINE, ETC.

THIS WATER METER SHOULD NOT BE USED AS THE PRIMARY MONITORING DEVICE FOR CRITICAL OR HEALTH EFFECT APPLICATIONS.

**OPERATING PRESSURES: 20 PSI MINIMUM - 125 PSI MAXIMUM (1.4 - 8.6 bar)
OPERATING TEMPERATURE 40°F MINIMUM - 110°F MAXIMUM (4° - 43°C)**

The 22 gauge wire crimp terminals are Molex Series 41572 or 40445. The housing connector is Molex Series 2695 White Housing, P/N 22-01-3037.

The housing connector diagram shows the proper installation of the RED, WHITE and BLACK wires for CLACK CORPORATION CONTROL VALVES. When connecting to other manufacturers control valves please contact your original equipment manufacturer for proper wiring instructions.

Wiring:

- The meter must be supplied with a DC voltage between 4 and 24 volts
- The RED wire is positive
- The BLACK wire is negative
- The WHITE wire is the meter output

Calibration:

- The calibration factor for the WS3 Meter Assembly is 8 pulses per gallon when used on applications other than Clack valves.
- The meter flow range is 3.5-350 gpm \pm 5% (output signal 0.46 Hz to 46.6 Hz). NOTE: Not all flow monitors will register accurately at either the low or high flow range of this meter. Contact your flow monitor manufacturer for limitations.
- Pressure drop at 350 gpm is 7.3 PSI

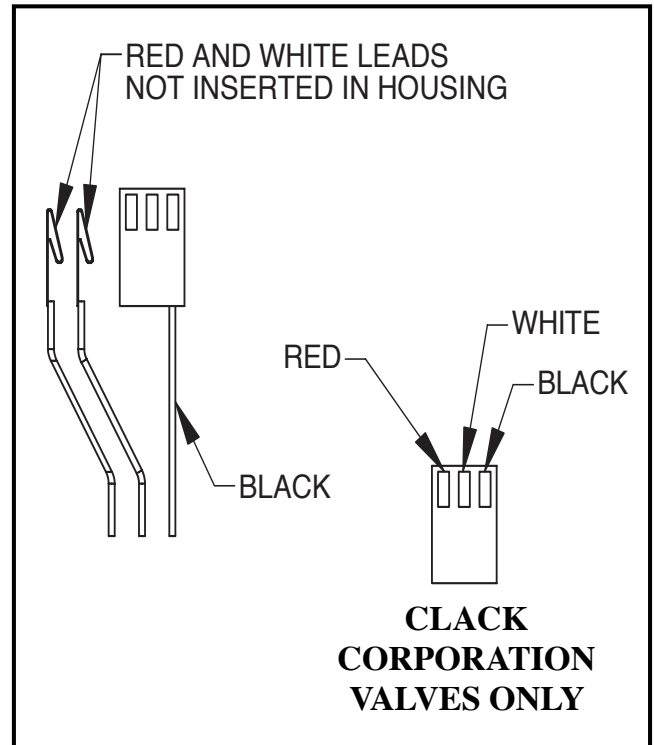

V3075 WS3 3" Meter NPT Assembly and V3075BSPT WS3 3" Meter BSPT Assembly

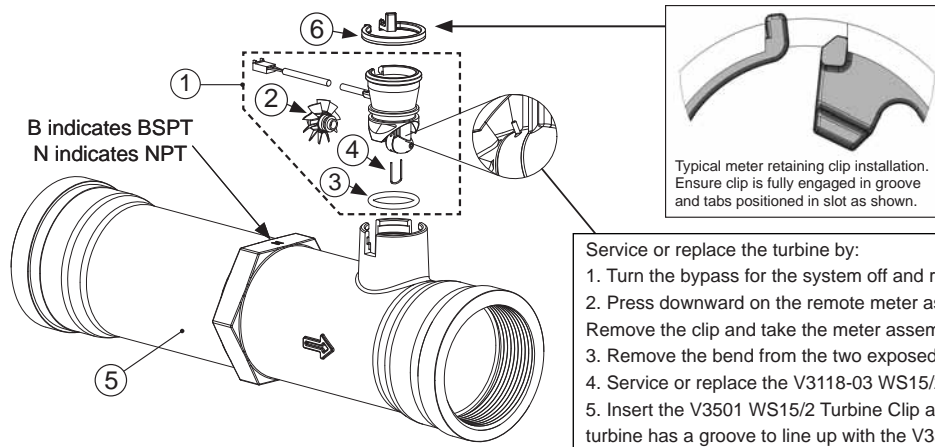

Service or replace the turbine by:

1. Turn the bypass for the system off and relieve the pressure on the system.
2. Press downward on the remote meter assembly to relieve tension on the retaining clip V3632. Remove the clip and take the meter assembly out of the housing.
3. Remove the bend from the two exposed tips of the retaining clip V3501 and remove clip.
4. Service or replace the V3118-03 WS15/2 Turbine Assembly and place it back in the turbine shaft.
5. Insert the V3501 WS15/2 Turbine Clip and re-bend the exposed ends of the clip. The V3118-03 turbine has a groove to line up with the V3501 WS15/2 Turbine Clip.
6. Insert meter assembly back into the meter housing.
7. Re-install the meter retaining clip V3632 as shown above.
8. Open the bypass for the system slowly to bring back into service and check to be sure you have no water leaks.

Drawing No.	Order No.	Description	Quantity
1	V3221	WS Remote Meter Asy 15 Ft Cord (includes V3118-03, V3501 and V3105)	1
2	V3118-03	WS1.5/2 Turbine Asy	1
3	V3105	O-Ring 215	1
4	V3501	WS1.5/2 Turbine Clip	1
5	V3601-01	WS3 Meter NPT Housing	1
	V3601BSPT-01	WS3 Meter BSPT Housing	
6	V3632	WS1.5/2/3 Meter Retaining Clip	
Not Shown	V3602	WS3 Flow Straightener (located inside meter housing)	1

Installation

Installation of the V3075 WS3 Meter NPT Assembly can be accomplished with 3" NPT pipe or by using a 3/2" groove lock coupling. For V3075BSPT WS3 Meter BSPT Assembly use 3" BSPT pipe or 3/2" groove lock coupling. It is recommended that the meter assembly be installed horizontally or in a downflow vertical position to reduce turbine bearing wear.

WHEN INSTALLING THE METER, MAKE SURE THE ARROW ON THE METER BODY IS GOING THE SAME DIRECTION AS THE WATER FLOW.

THIS WATER METER SHOULD NOT BE USED AS THE PRIMARY MONITORING DEVICE FOR CRITICAL OR HEALTH EFFECT APPLICATIONS.

OPERATING PRESSURES: 20 PSI MINIMUM / 125 PSI MAXIMUM

OPERATING TEMPERATURES: 40°F MINIMUM / 110°F MAXIMUM

The 22 gauge wire crimp terminals are Molex Series 41572 or 40445. The housing connector is Molex Series 2695 White Housing, P/N 22-01-3037.

The housing connector diagram shows the proper installation of the RED, WHITE and BLACK wires for CLACK CORPORATION CONTROL VALVES. When connecting to other manufacturers control valves please contact your original equipment manufacturer for proper wiring instructions.

Wiring:

- The meter must be supplied with a DC voltage between 4 and 24 volts
- The RED wire is positive
- The BLACK wire is negative
- The WHITE wire is the meter output

Calibration:

- For WS2H valves select 8 pulses if valve software records in gallons and 2.1 if valve software records in liters.
- The calibration factor for the WS3 Meter Assembly is 8 pulses per gallon when used on applications other than WS2H valves.
- The meter flow range is 3.5-350 gpm ± 5% (output signal 0.46 Hz to 46.6 Hz). NOTE: Not all flow monitors will register accurately at either the low or high flow range of this meter. Contact your flow monitor manufacturer for limitations.
- Pressure drop at 350 gpm is 7.3 PSI

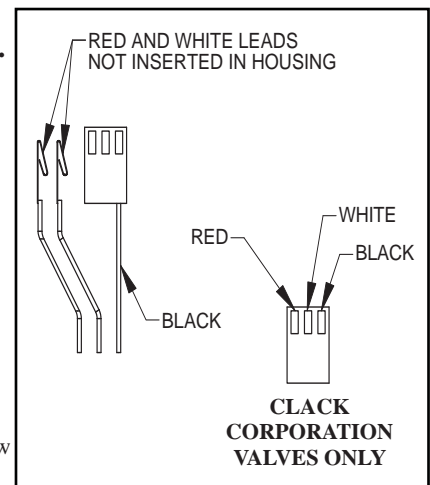

WS2H and WS3 Brine Valve Body and Injector Components

Drawing No.	Order No.	Description	Quantity	
			WS2H	WS3
1	V3237-01	WS2H/3 SOFTFILL TUBE ASY	1	1
2a	V3236-04***	WS2H INJECTOR TUBE ASY FOR A THRU H	1	
2b	V3670-01	WS3 INJECTOR TUBE DOWNFLOW ASY		1
3	V3289	O-RING 344	1	1
4	V3067	WS2H/3 BRINE BODY ASY	1	1
5	V3477	WS2H/3 INJECTOR CAP	1	1
6	V3152	O-RING 135	1	1
7	V3275	WS2H/3 SCREW BSHD SS 3/8-16X2-1/4 (7/32" hex allen wrench required)	4	4
8	V3291	WS2H/3 WASHER SS 3/8	4	4
9	V3162-022*	WS1 DLFC 022 FOR 3/4	1	1
10	V3231	WS2H/3 REFILL FLOW CNTRL RETAINER	1	1
11	V3277	O-RING 211	1	1
12	V3105	O-RING 215	1	1
13	V3150	WS1 SPLIT RING	1	1
14	V3151	WS1 NUT 1 QC	1	1
15	V3149	WS1 FTG 1 PVC MALE NPT ELBOW	1	1
Not Shown	V3189	WS1 FTG 3/4&1 PVC SLVNT 90	Optional	Optional
16	V3010-2R-15B	WS2 INJECTOR R ASY W/V3010-15B	1	1
	V3010-2S-15C	WS2 INJECTOR S ASY W/V3010-15C		
	V3010-2T-15D	WS2 INJECTOR T ASY W/V3010-15D		
	V3010-2U-15E	WS2 INJECTOR U ASY W/V3010-15E		
	V3010-2V-15F	WS2 INJECTOR V ASY W/V3010-15F		
	V3010-2W-15G	WS2 INJECTOR W ASY W/V3010-15G		
	V3010-2X-15H	WS2 INJECTOR X ASY W/V3010-15H		
	V3010-2A	WS2/2H/3 INJECTOR ASY A		
	V3010-2B	WS2/2H/3 INJECTOR ASY B		
	V3010-2C	WS2/2H/3 INJECTOR ASY C		
V3010-2D	WS2/2H/3 INJECTOR ASY D			
V3010-2E	WS2/2H/3 INJECTOR ASY E			
V3010-2F	WS2/2H/3 INJECTOR ASY F			
V3010-2G	WS2/2H/3 INJECTOR ASY G			
V3010-2H	WS2/2H/3 INJECTOR ASY H			
Not Shown	V3499**	WS2H/3 FITTING CAP I IN THREADED	1	1

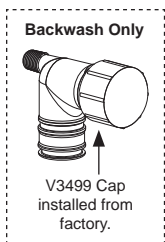

Proper RFC orientation directs refill water flow towards the washer face with radius and text.

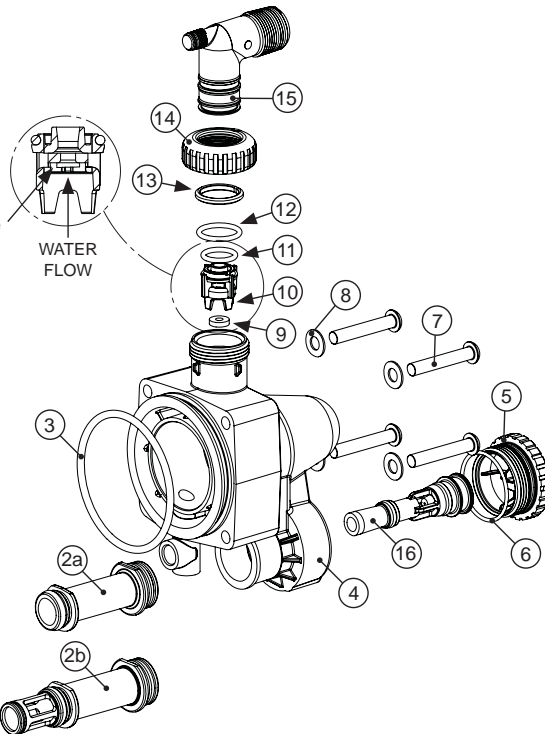

***V3236-01. Could be used "as is" with A-C injectors. Diffuser is snipped off if using D through G injectors. Order V3236-04 if using H injector.

*Any V3162-XXX flow control may be used. V3237-01 WS2H SOFTFILL TUBE ASY contains a V3155 O-RING 112, V3287 O-RING 110 and a V3288 O-RING 206.

V3236-04 WS2H INJECTOR TUBE ASY A thru H contains a V3285 O-RING 213 and a V3286 O-RING 216.

V3670-01 WS3 INJECTOR TUBE DOWNFLOW ASY contains a V3285 O-RING 213, V3286 O-RING 216 and a V3163 O-RING 019.

V3010-2A through V3010-2G injectors and the V3010-15ADAPTER contain a V3283 O-RING 117 and a V3284 O-RING 114. The V3010-15ADAPTER can be used with any V3010-15X injector so the 2H valve can be used on smaller tank sizes. The V3010-15X injector contains one V3416 O-RING 012 (lower) and one V3171 O-RING 013 (upper). V3010-2H injectors use a V3283 O-RING 117 and D1263 O-RING 116.

Backwash Only Valves include a V3499 but do not include the following parts: V3189, V3162-022, V3231 and V3277.

** Install V3499 on V3149 if valve is to be set up as a backwash only valve

V3064 WS2H/2QC 4 INCH BASE ASY (For use on WS2H or WS2QC only)

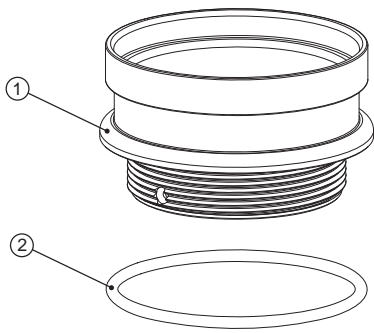

Drawing No.	Order No.	Description	Quantity
1	V3202-01	WS2H BASE	1
2	V3281	O-RING 348	1

V3055 WS2H/2QC 6 INCH FLANGE BASE ASY or V3090 WS3 6 INCH FLANGE BASE ASY

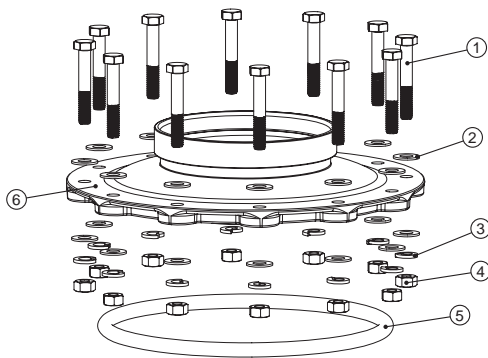

Drawing No.	Order No.	Description	Quantity	
			V3055	V3090
1	V3444	WS2H SCREW HEXCAP 5/16-18X2 SS	12	12
2	V3293	WS2H WASHER SS 5/16 FLAT	24	24
3	V3445	WS2H WASHER SPLIT LOCK 5/16 SS	12	12
4	V3447	WS2H NUT HEX 5/16-8 FULL SS	12	12
5	COR60FL	O RING 6 FLANGE ADAPTER(PARK)	1	1
6	V3261-01	WS2H FLANGE BASE	1	
	V3671-01	WS3 FLANGE BASE		1

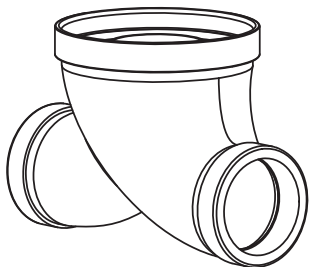

Order No.	Description	Inlet/Outlet	For Valve
V3260-02	WS2H/2QC SIDE MOUNT NPT ASY	2" Female NPT or 2.5" Groove Lock	WS2H NPT
V3674-02	WS3 SIDE MOUNT NPT ASY	3" Female NPT	WS3 NPT
V3674BSPT-02	WS3 SIDE MOUNT BSPT ASY	3" Female BSPT	WS3 BSPT

V3260BSPT-02 WS2H SIDE MOUNT BASE BSPT ASY

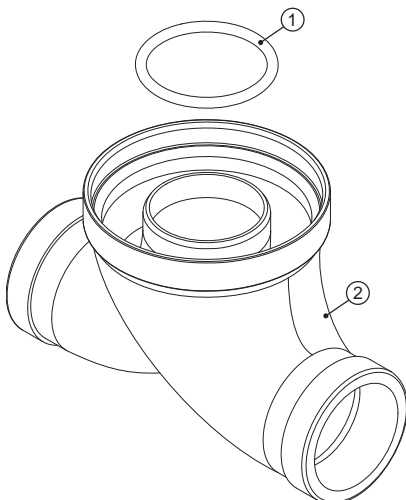

Drawing No.	Order No.	Description	Quantity
1	V3280	O-RING 332	1
2	V3260BSPT-01	WS2H SIDE MOUNT BASE BSPT	1

When using a side mount base with 2H BSPT valves replace distributor pilot o-ring V3452 O-RING 230 with V3280 O-RING 332. See exploded view of 2H valve for specific location of distributor pilot o-ring.

Order No. V3158-04

Description: WS2 Drain Elbow 3/4" Male NPT without Silencer

DRAWING NUMBER	ORDER NUMBER	DESCRIPTION	QTY
1	V3649	BUSHING PVC SCH80 1.5/1.25 NPT	1
2	V3414	WS15 DLFC ADAPTER	1
3	H4615	CLIP RETAINING 474/WS1	1
4	V3162-007	WS1 DLFC 0.7 gpm for 3/4	ONE DLFC MUST BE USED IF 3/4" FITTING IS USED.
	V3162-010	WS1 DLFC 1.0 gpm for 3/4	
	V3162-013	WS1 DLFC 1.3 gpm for 3/4	
	V3162-017	WS1 DLFC 1.7 gpm for 3/4	
	V3162-022	WS1 DLFC 2.2 gpm for 3/4	
	V3162-027	WS1 DLFC 2.7 gpm for 3/4	
	V3162-032	WS1 DLFC 3.2 gpm for 3/4	
	V3162-042	WS1 DLFC 4.2 gpm for 3/4	
	V3162-053	WS1 DLFC 5.3 gpm for 3/4	
	V3162-065	WS1 DLFC 6.5 gpm for 3/4	
	V3162-075	WS1 DLFC 7.5 gpm for 3/4	
V3162-090	WS1 DLFC 9.0 gpm for 3/4		
V3162-100	WS1 DLFC 10 gpm for 3/4		
5	V3159-01	WS1 DLFC RETAINER ASY	1
6	V3163	O-RING 019	1
7	V3158-03	WS1 DRN ELBOW 3/4 MALE NO HOLE	1

This assembly is shipped without drain line flow control (DLFC) – install DLFC before using. Use a minimum drain line size of 3/4".

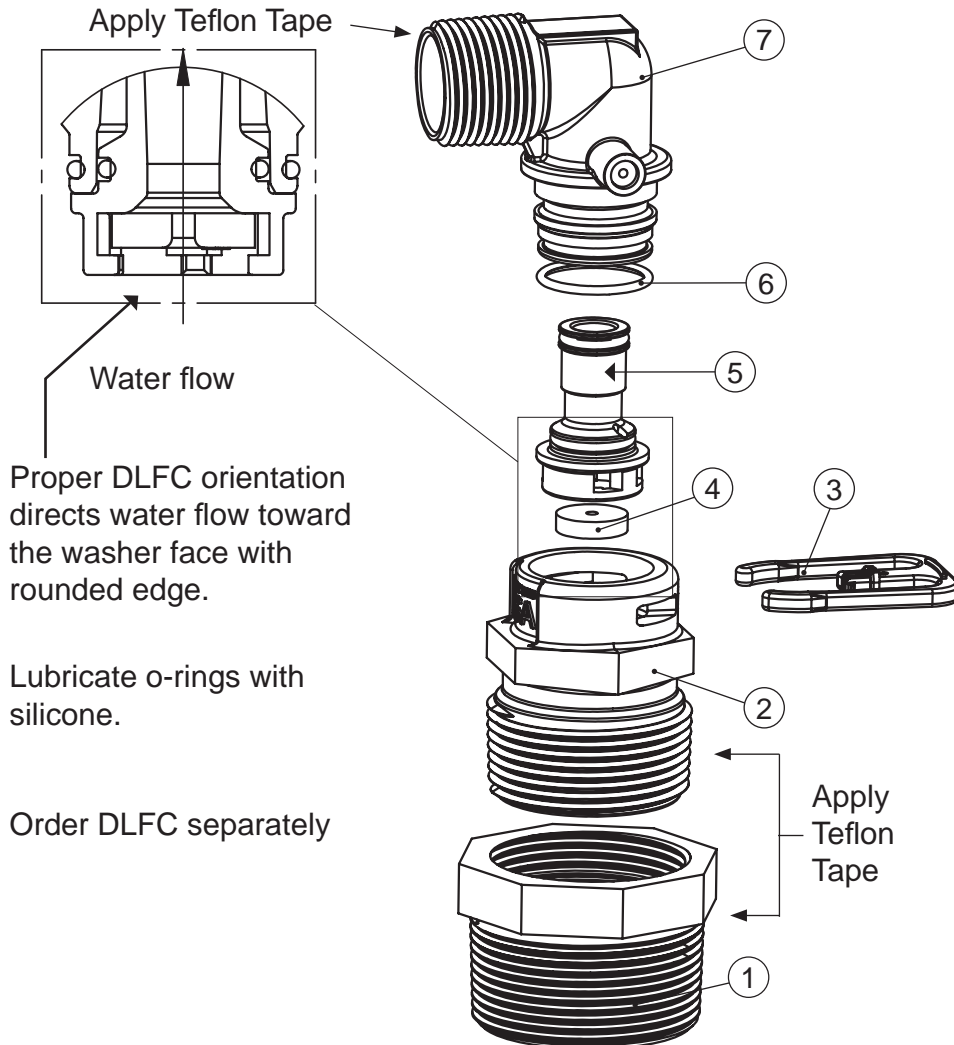

Order No. V3008-05

Description: WS2 Drain Fitting 1" Male NPT Straight without Silencer

DRAWING NUMBER	ORDER NUMBER	DESCRIPTION	QTY
1	V3166-01	WS1 FTG FLOW CONTROL BODY	1
2	V3167	WS1 DRAIN FTG ADAPTER 1	1
3	V3163	O-RING 019	1
4	V3150	WS1 SPLIT RING	1
5	V3151	WS1 NUT 1" QC	1
6	V3105	O-RING 215	1
7*	V3190-090	WS1 DLFC 9.0 GPM FOR 1	ONE DLFC MUST BE USED IF 1" FITTING IS USED.
	V3190-100	WS1 DLFC 10.0 GPM FOR 1	
	V3190-110	WS1 DLFC 11.0 GPM FOR 1	
	V3190-130	WS1 DLFC 13.0 GPM FOR 1	
	V3190-150	WS1 DLFC 15.0 GPM FOR 1	
	V3190-170	WS1 DLFC 17.0 GPM FOR 1	
	V3190-200	WS1 DLFC 20.0 GPM FOR 1	
	V3190-250	WS1 DLFC 25.0 GPM FOR 1	
8	H4615	CLIP RETAINING	1
9	V3414	WS1.5 DLFC ADAPTER	1
10	V3649	BUSHING PVC SCH 80 1.5 TO 1.25 NPT	1

* Order DLFC separately.

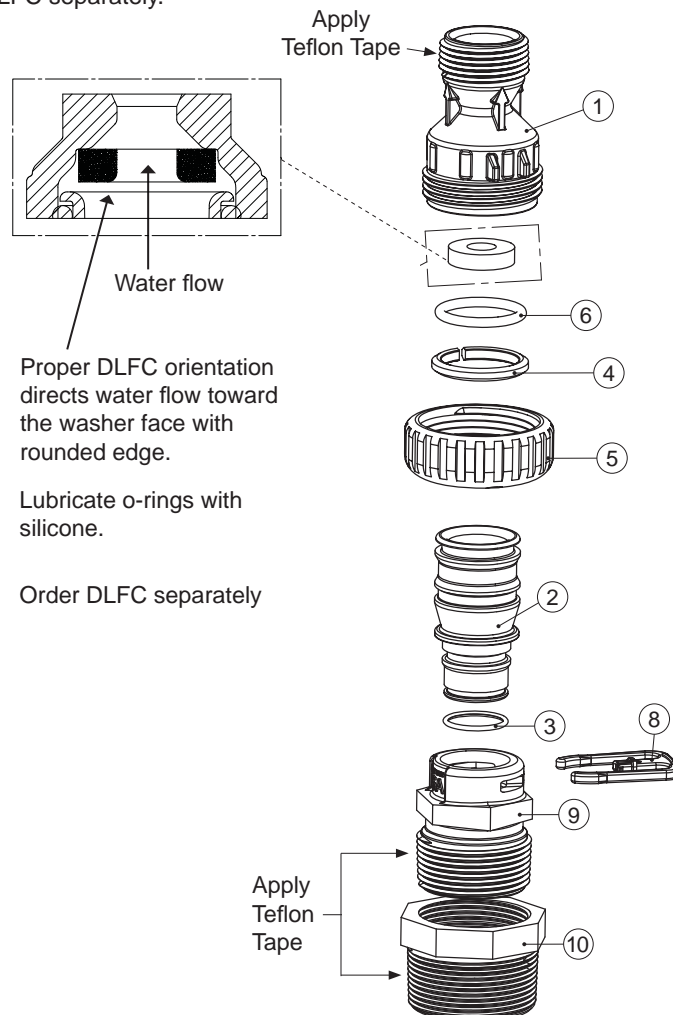

V3079 WS DLFC ASY 125 FNPT/15 FNPT, V3079BSPT WS DLFC ASY 125 FNPT/15 FBSPT, V3080 WS DLFC ASY 15 MNPT/15 FNPT and V3080BSPT WS DLFC ASY 15 MNPT/15 FBSPT

Drawing No.	Order No.	Description	Quantity			
			V3079	V3079BSPT	V3080	V3080BSPT
1	V3081	WS15 RETAINER DLFC ASY	1	1	1	1
2	V3645	WS15 DLFC FLANGE OUTLET FNPT	1		1	
	V3645BSPT	WS15 DLFC FLANGE OUTLET FBSPT		1		1
3	V3646	WS15 DLFC FLANGE INLET MNPT			1	1
4	V3647	WS125 DLFC FLANGE INLET FNPT	1	1		
5	V3652	BOLT HEXHD S/S HCS 5/16-18x3/4	4	4	4	4
6	V3441	O-RING 226	1	1	1	1
Not Shown	V3162-007	WS1 DLFC 0.7 gpm for 3/4	Install at least one V3190-XXX in center hole. Knock out plugs allow installation of up to 6 more of V3162-XXX.			
	V3162-010	WS1 DLFC 1.0 gpm for 3/4				
	V3162-013	WS1 DLFC 1.3 gpm for 3/4				
	V3162-017	WS1 DLFC 1.7 gpm for 3/4				
	V3162-022	WS1 DLFC 2.2 gpm for 3/4				
	V3162-027	WS1 DLFC 2.7 gpm for 3/4				
	V3162-032	WS1 DLFC 3.2 gpm for 3/4				
	V3162-042	WS1 DLFC 4.2 gpm for 3/4				
	V3162-053	WS1 DLFC 5.3 gpm for 3/4				
	V3162-065	WS1 DLFC 6.5 gpm for 3/4				
	V3162-075	WS1 DLFC 7.5 gpm for 3/4				
	V3162-090	WS1 DLFC 9.0 gpm for 3/4				
	V3162-100	WS1 DLFC 10.0 gpm for 3/4				
	V3190-090	WS1 DLFC 09.0 gpm for 1				
	V3190-100	WS1 DLFC 10.0 gpm for 1				
	V3190-110	WS1 DLFC 11.0 gpm for 1				
	V3190-130	WS1 DLFC 13.0 gpm for 1				
	V3190-150	WS1 DLFC 15.0 gpm for 1				
V3190-170	WS1 DLFC 17.0 gpm for 1					
V3190-200	WS1 DLFC 20.0 gpm for 1					
V3190-250	WS1 DLFC 25.0 gpm for 1					

Assemblies are shipped without drain line flow control (DLFC). Assembly instructions:

- Determine the desired flow rate. Select one V3190-XXX for the center hole and a combination of V3162-XXX to arrive at the desired flow rate. At least one V3190-XXX must be used and up to six of the V3162-XXX may be used.
- Using a drill or punch remove the desired knockout(s) in V3081.
- Smooth holes.
- Install appropriate size(s) of drain line flow control washers. Play close attention to proper DLFC orientation.
- Fit V3441 o-ring onto V3081 Retainer DLFC Asy and assemble. Properly orientate the V3081 in direction of flow.
- Inlet threads for 1.25" female are NPT. Inlet threads for 1.5" male are NPT. Outlet threads for 1.5" are either female NPT or BSPT. 1.5" female outlet is stamped with N or B to indicate NPT or BSPT.

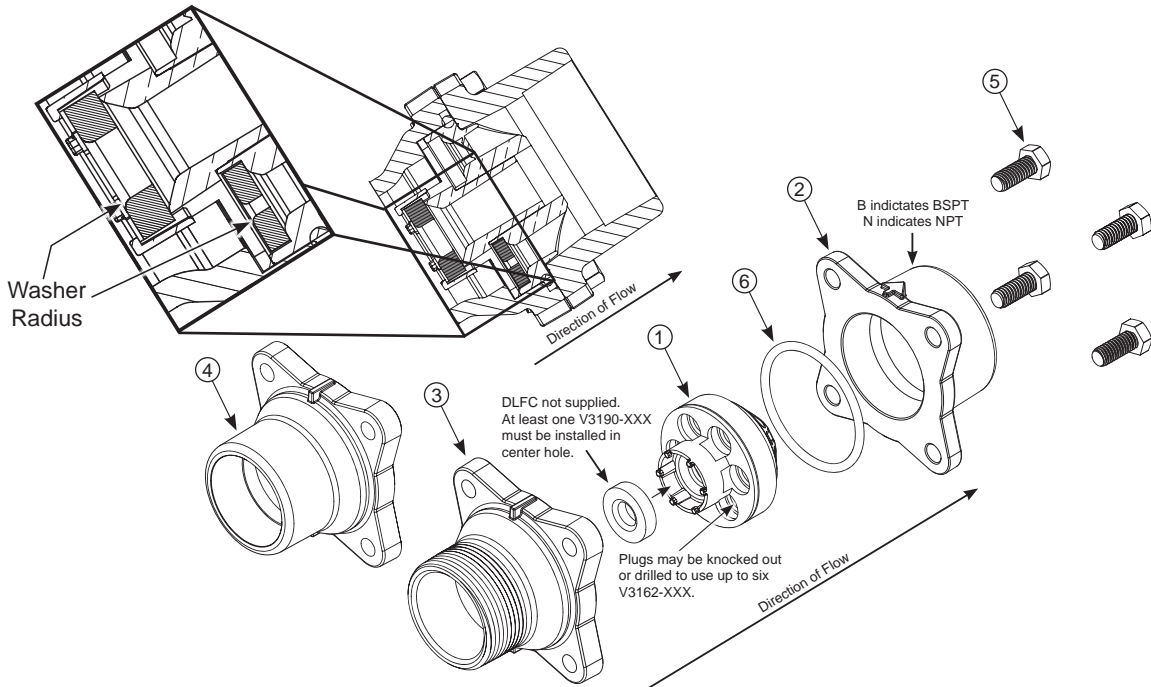

V3051 WS2 DLFC ASY NPT and V3051BSPT WS2 DLFC ASY BSPT

Drawing No.	Order No.	Description	Quantity
1	V3052	WS2 DLFC Retainer ASY	1
2	V3245	WS2 DLFC FLANGE INLET NPT	1
	V3245BSPT	WS2 DLFC FLANGE INLET BSPT	
3	V3246	WS2 DLFC FLANGE OUTLET NPT	1
	V3246BSPT	WS2 DLFC FLANGE OUTLET BSPT	
4	V3273	BOLT HEX HD S/S HCS 3/8-16X3/4	4
5	V3278	O-ring 338	1
Not Shown	V3162-007	WS1 DLFC 0.7 gpm for 3/4	Install One or More DLFC's.
	V3162-010	WS1 DLFC 1.0 gpm for 3/4	
	V3162-013	WS1 DLFC 1.3 gpm for 3/4	
	V3162-017	WS1 DLFC 1.7 gpm for 3/4	
	V3162-022	WS1 DLFC 2.2 gpm for 3/4	
	V3162-027	WS1 DLFC 2.7 gpm for 3/4	
	V3162-032	WS1 DLFC 3.2 f gpm or 3/4	
	V3162-042	WS1 DLFC 4.2 gpm for 3/4	
	V3162-053	WS1 DLFC 5.3 gpm for 3/4	
	V3162-065	WS1 DLFC 6.5 gpm for 3/4	
	V3162-075	WS1 DLFC 7.5 gpm for 3/4	Up to 5 of the V3162-XXX may be installed in the small holes. Up to 4 of the V3190-XXX may be installed in the large holes.
	V3162-090	WS1 DLFC 9.0 gpm for 3/4	
	V3162-100	WS1 DLFC 10.0 gpm for 3/4	
	V3190-090	WS1 DLFC 9.0 gpm for 1	
	V3190-100	WS1 DLFC 10.0 gpm for 1	
	V3190-110	WS1 DLFC 11.0 gpm for 1	
	V3190-130	WS1 DLFC 13.0 gpm for 1	
	V3190-150	WS1 DLFC 15.0 gpm for 1	
	V3190-170	WS1 DLFC 17.0 gpm for 1	
	V3190-200	WS1 DLFC 20.0 gpm for 1	
V3190-250	WS1 DLFC 25.0 gpm for 1		

Assemblies are shipped without drain line flow control (DLFC). Assembly instructions:

1. Determine the desired flowrate. Select a combination of V3162-XXX's and V3190-XXX's to arrive at the desired flow rate. Up to five of the smaller V3162-XXX's may be used. Up to four of the larger V3190-XXX's may be used.
2. Using a drill or punch remove the desired knockout(s) in V3052.
3. Smooth hole(s).
4. Install appropriate size(s) of drain line flow control washers. Pay close attention to proper DLFC orientation.
5. Assemble. Properly orientate the V3052 in the direction of flow.
6. Inlet and outlet threads are 2". Couplings for iron pipe may also be used.

B indicates BSPT
N indicates NPT

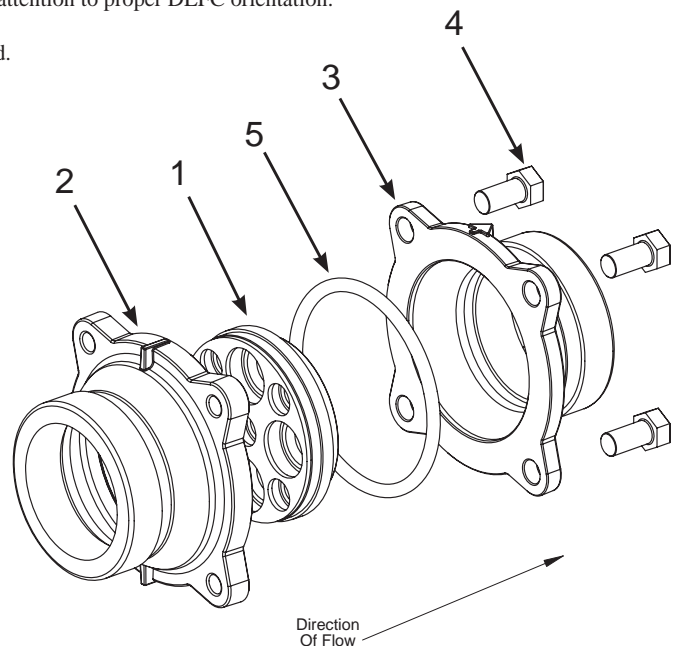
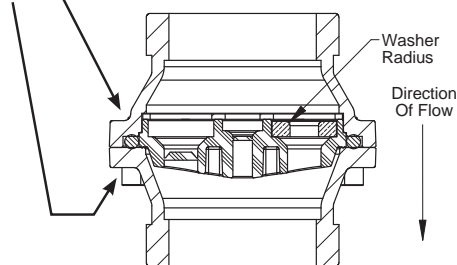

V3764 WS3 DLFC NPT ASY or V3764BSPT WS3 DLFC BSPT ASY

Drawing No.	Order No.	Description	Quantity
1	V3190-090	WS1 DLFC 9.0 gpm for 1	Install One or More DLFC washers. DLFC washers must be purchased separately. When using one retainer and one o-ring up to 5 DLFC washers can be used for flow rates from 9 gpm up to 125 gpm. When using two retainers and two o-rings, 5 DLFC washers are used in one of the retainers and up to 4 more DLFC washers can be used in the other retainer for flow rates from 9 gpm up to 225 gpm.
	V3190-100	WS1 DLFC 10.0 gpm for 1	
	V3190-110	WS1 DLFC 11.0 gpm for 1	
	V3190-130	WS1 DLFC 13.0 gpm for 1	
	V3190-150	WS1 DLFC 15.0 gpm for 1	
	V3190-170	WS1 DLFC 17.0 gpm for 1	
	V3190-200	WS1 DLFC 20.0 gpm for 1	
	V3190-250	WS1 DLFC 25.0 gpm for 1	
2	V3765-01	WS3 DLFC HOUSING NPT	1
	V3765BSPT-01	WS3 DLFC HOUSING BSPT	
3	V3766	WS3 DLFC RETAINER	1 or 2
4	V3767	WS3 DLFC RETAINER COVER	1
5	V3768	WS3 DLFC RETAINER RING	1
6	V3769	O-RING 336	1 or 2

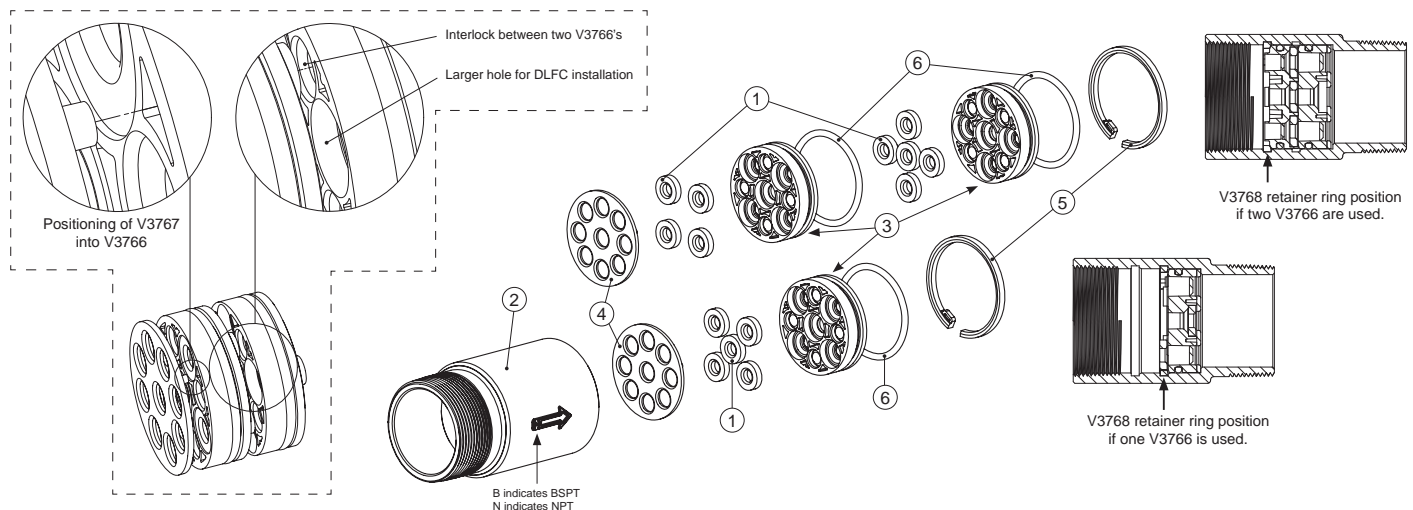

Assemblies are shipped without drain line flow control (DLFC) washers.

Assembly instructions:

- Determine the desired flow rate. Select a combination of V3190-XXX's to arrive at the desired flow rate.
- Using a drill or punch remove the desired knockout(s) in V3766. Each V3766 retainer contains two types of knockouts. The larger knockouts are removed to install a DLFC. If two V3766 retainers are needed remove the smaller diameter knockout that lines up with the DLFC installed in the other retainer. One or two V3766 retainers may be used. When using one V3766 retainer V3190-XXX must be installed in the center hole. When using two V3766 retainers a V3190-XXX must be installed in the center hole of one of the retainers and the center hole on the other retainer must remain open.
- Smooth hole(s).
- Install appropriate size(s) of drain line flow control washers. Pay close attention to proper DLFC orientation.
- Assemble. Each V3766 retainer must have a V3769 o-ring installed. One each of the V3767 retainer cover and V3768 retainer ring must be used whether one or two V3766 retainers are used. The positioning of the V3768 retainer ring varies depending on the number of V3766 retainer(s) used. Properly orientate the V3766(s) in the direction of flow.
- Properly orientate the complete assembly in the direction of flow. Inlet and outlet threads are 3".

V3063 MOTOR ALTERNATING VLV 2 NPT and V3063BSPT MOTOR ALTERNATING VLV 2 BSPT

Drawing No.	Order No.	Description	Quantity
1	V3056	WS1.5&2ALT/2BYPASS AUTO CVRASY	1
2	V3476	WS MOTOR ASY 8 FT	1
3	V3272	WS2 SCREW 8X1 SS HEX SELF TAP	3
4	V3262-01	WS1.5&2ALT/2BY REDUCGEARCVRASY	1
5	V3110	WS1 DRIVE REDUCING GEAR 12X36	3
6	V3264	WS2 BYPASS REDUCTION GEAR AXLE	3
7	V3292	WS2 SCREW BSHD SS 1/4-20X1-1/2	4
8	V3059	WS1.5&2ALT/2BYPAS AUTODRIVEASY	1
9	V3298-01	WS2 ALT VALVE BODY NPT	1
	V3298BSPT-01	WS2 ALT VALVE BODY BSPT	
Not Shown	V3474	WS ALT CONNECT CORD 8 FT BLK	1

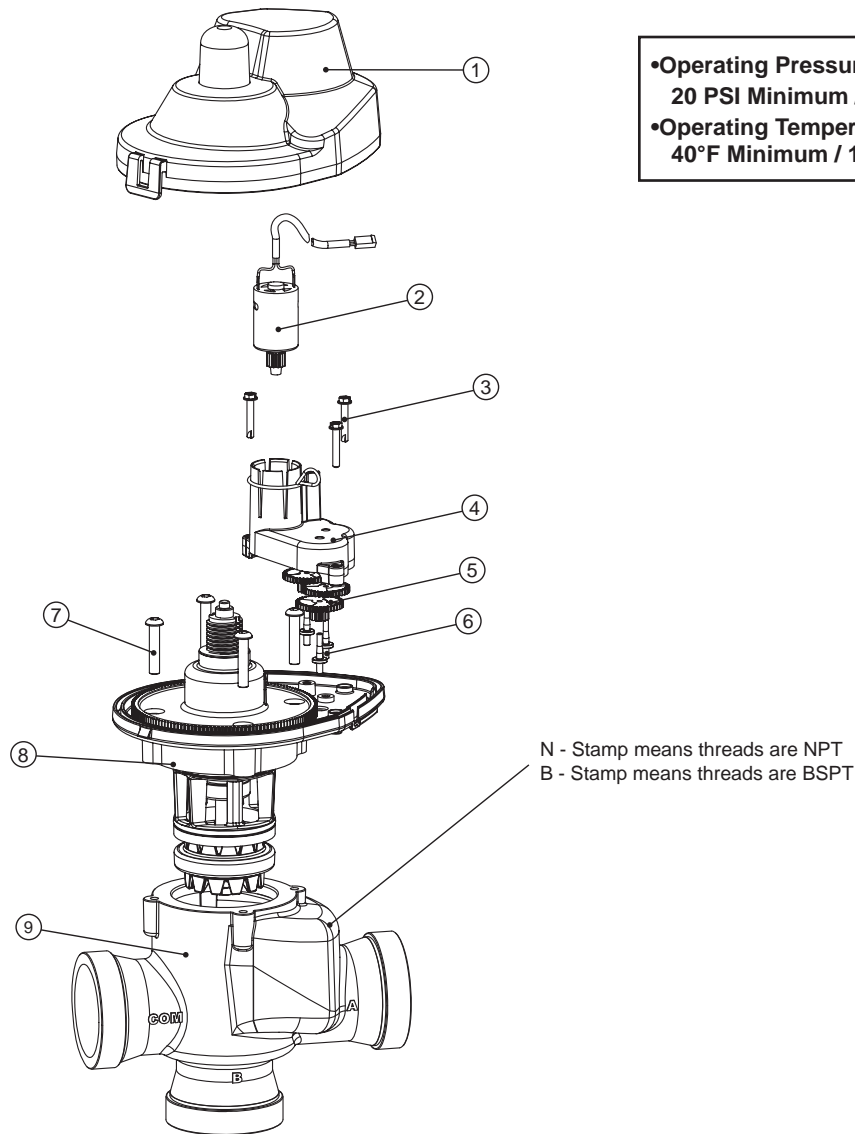

•Operating Pressures:
 20 PSI Minimum / 125 PSI Maximum
 •Operating Temperatures:
 40°F Minimum / 110°F Maximum

Order No. V3076 • Description: MOTOR ALT VLV 2 NPT REV2 or
 Order No. V3076BSPT • Description: MOTOR ALT VLV 2 BSPT REV2

Drawing No.	Order No.	Description	Quantity	
			V3076	V3076BSPT
1	V3073	MAV/NOHWBY COVER ASY	1	1
2	V3476	WS MOTOR ASY 8 FT	1	1
3	V3592	SCREW #8-3/4 PHPN T-25 SS	3	3
4	V3262-01	WS1.5&2ALT/2BY REDUCGEARCVRASY	1	1
5	V3110	WS1 DRIVE REDUCING GEAR 12X36	3	3
6	V3264	WS2 BYPASS REDUCTION GEAR AXLE	3	3
7	V3642	SCREW 1/4-20 X 1 1/4 BHSCS SS	4	4
8	V3078	MAV/NOHWBY 2 DRIVE ASY	1	1
9	V3634-01	MAV/NOHWBY 2 PISTON	1	1
10	V3077	MAV/NOHWBY 2 STACK ASY	1	1
11	V3633-01	WS2 MAV BODY NPT	1	N/A
	V3633-01BSPT	WS2 MAV BODY BSPT	N/A	1
Not Shown	V3474	WS ALT CONNECT CORD 8FT BLK	1	1

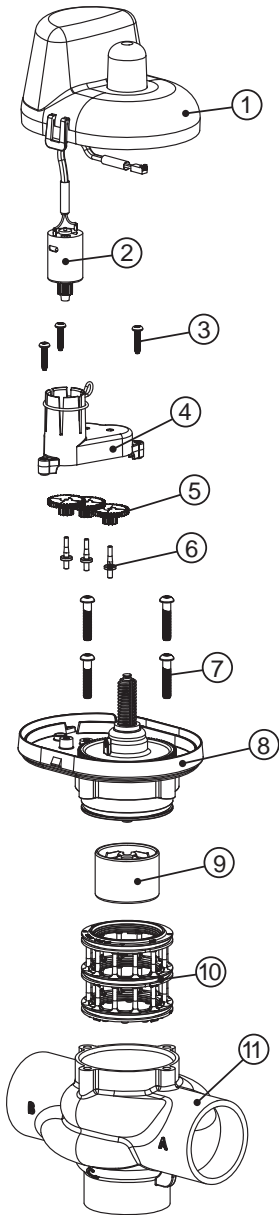

•Operating Pressures:
 20 PSI Minimum / 125 PSI Maximum
•Operating Temperatures:
 40°F Minimum / 110°F Maximum

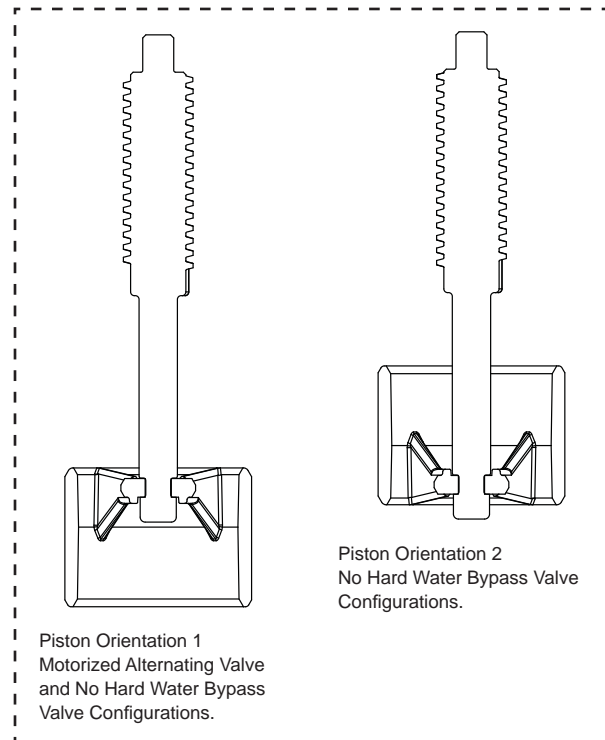

Order No. V3083 • Description: MOTOR ALT VLV 3 NPT or
 Order No. V3083BSPT • Description: MOTOR ALT VLV 3 BSPT

Drawing No.	Order No.	Description	Quantity	
			V3083	V3083BSPT
1	V3696	WS3 MAV COVER	1	1
2	V3476	WS MOTOR ASY 8 FT	1	1
3	V3592	SCREW #8-3/4 PHPN T-25 SS	3	3
4	V3262-01	WS 1.5&2ALT/2BY REDUCGEARCVASY	1	1
5	V3110	WS1 DRIVE REDUCING GEAR 12X36	3	3
6	V3264	WS2 BYPASS REDUCTION GEAR AXLE	3	3
7	V3789	SCREW 3/8-16 X 1.75 BHCS SS (7/32" hex allen wrench required)	4	4
8	V3085	WS3 MAV DRIVE CAP ASY	1	1
9	V3695-01	WS3 MAV PISTON	1	1
10	V3084	WS3 MAV STACK ASY	1	1
11	V3693-01	WS3 MAV BODY NPT	1	N/A
	V3693BSPT-01	WS3 MAV BODY BSPT	N/A	1
Sold Separately	V3475-12	WS2H/WS3 SYSTEM CONNECTION CORD 12 FOOT RED	One must be used for twin tank operation.	
	V3475-24	WS2H/WS3 SYSTEM CONNECTION CORD 24 FOOT BLUE		
	V3475-36	WS2H/WS3 SYSTEM CONNECTION CORD 36 FOOT YELLOW		

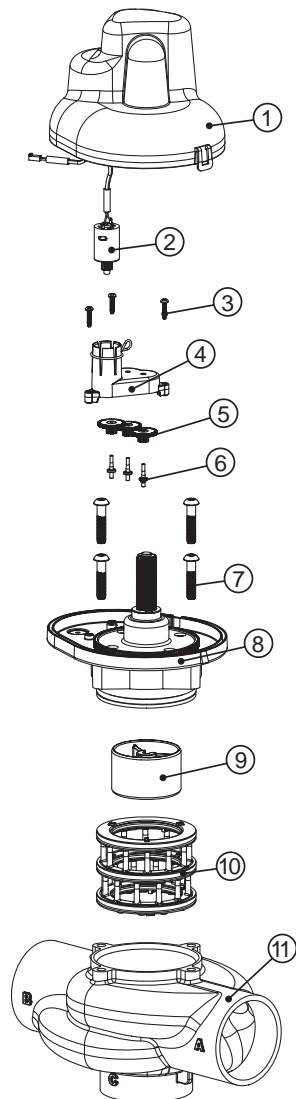

•Operating Pressures:
 20 PSI Minimum / 125 PSI Maximum
•Operating Temperatures:
 40°F Minimum / 110°F Maximum

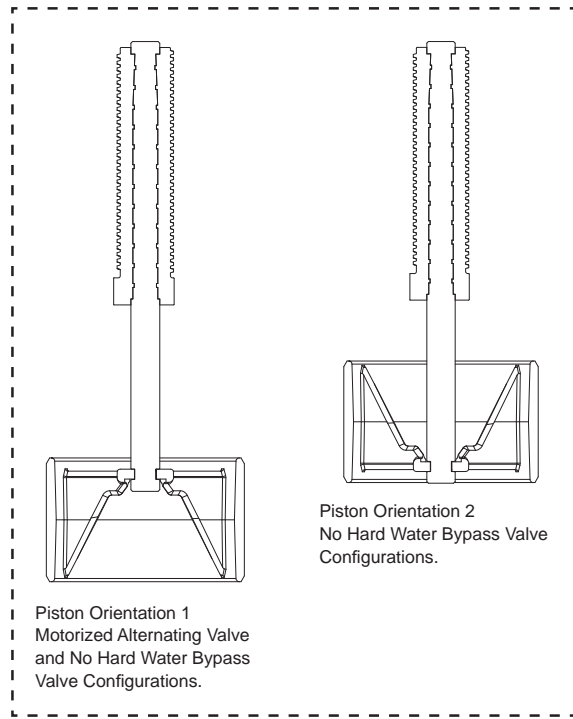

V3060 WS2H BYPASS AUTO NPT, V3060BSPT WS2H BYPASS AUTO BSPT, V3061BSPT WS2H BYPASS MANUAL BSPT and V3061 WS2H BYPASS MANUAL NPT

Drawing No.	Order No.	Description	Quantity	
			V3060	V3061
1	V3056	WS1.5&2ALT/2BYPASS AUTO CVRASY	1	N/A
2	V3476	WS MOTOR ASY 8 FT	1	N/A
3	V3272	WS2H SCREW 8X1 SS HEX SELF TAP	3	N/A
4	V3262-01	WS1.5&2ALT/2BY REDUCGEARCVRASY	1	N/A
5	V3110	WS1 DRIVE GEAR 12X36	3	N/A
6	V3264	WS2H BYPASS REDUCTION GEAR AXLE	3	N/A
7	V3292	WS2H SCREW BSHD SS 1/4-20X1-1/2	8	8
8	V3059	WS1.5&2ALT/2BYPAS AUTODRIVEASY	1	N/A
9	V3268	WS2H BYPASS COVER DOME MANUAL	1	2
10	V3058	WS2H BYPASS MANUAL DRIVE ASY	1	2
11	V3057	WS2H BYPASS BODY ASY NPT	1	1
	V3057BSPT	WS2H BYPASS BODY ASY BSPT		
Not Shown	V3053	WS2H 2-1/2 GROOVELOCK CLAMP ASY	2	2

Treated water is used for refill whether or not an auto or manual bypass is installed to either the inlet or outlet of a control valve. The Auto Drive Assembly may be connected to the inlet or outlet of the control valve to achieve no hard water bypass. If the Auto Drive Assembly is connected to the control valve:

- inlet then all regeneration cycles occur with treated water.
- outlet then all regeneration cycles except for refill occur with untreated water.

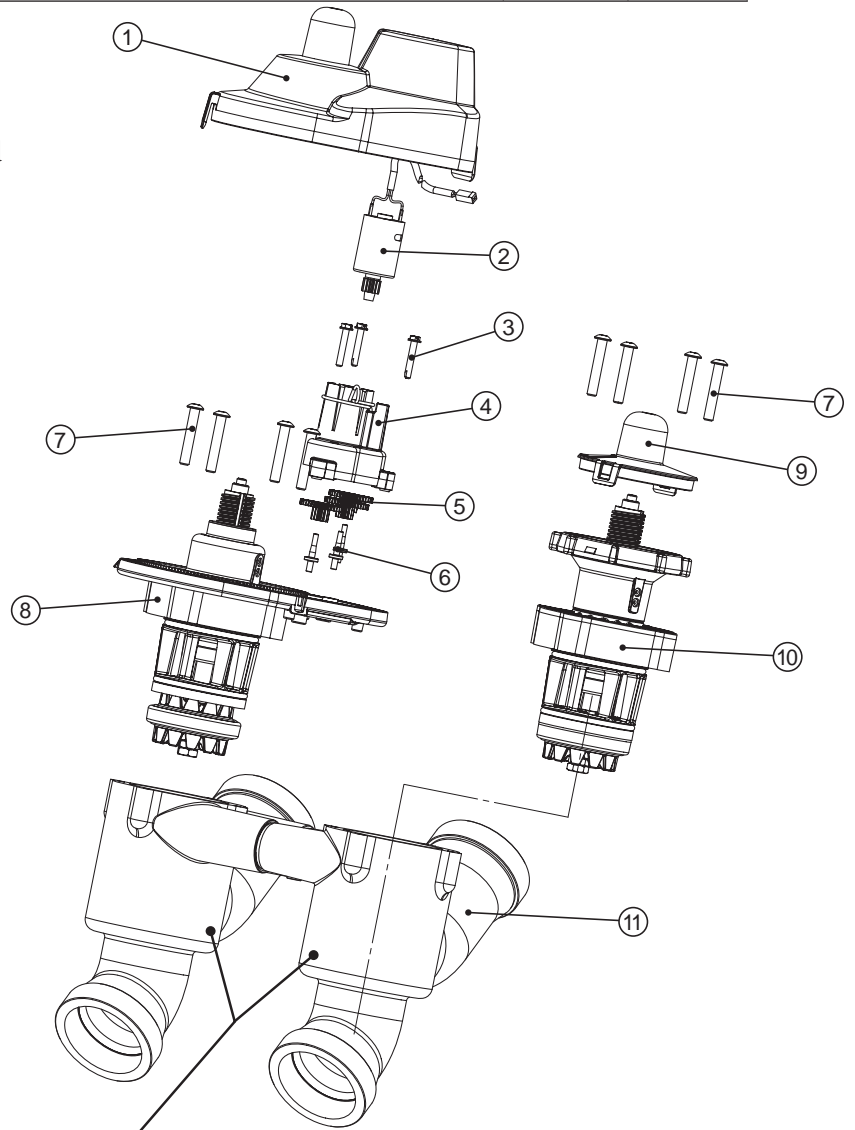

B indicates BSPT
N indicates NPT

V3053 WS2 2-1/2 GROOVELOCK CLAMP ASY

Drawing No.	Order No.	Description	Quantity
1	V3053	WS2 2-1/2 GROOVELOCK CLAMP ASY	1
2	V3290	WS2 GROOVE LOCK SEAL 2.5	1
3	V3269	WS2H NUT 5/16-18 SS HEX	1
4	V3293	WS2H WASHER SS 5/16 FLAT	1
5	V3276	WS2H BOLT HEX SS 5/16-18X1-3/4	1
Not Shown	S3086	SILICONE LUBRICANT	1

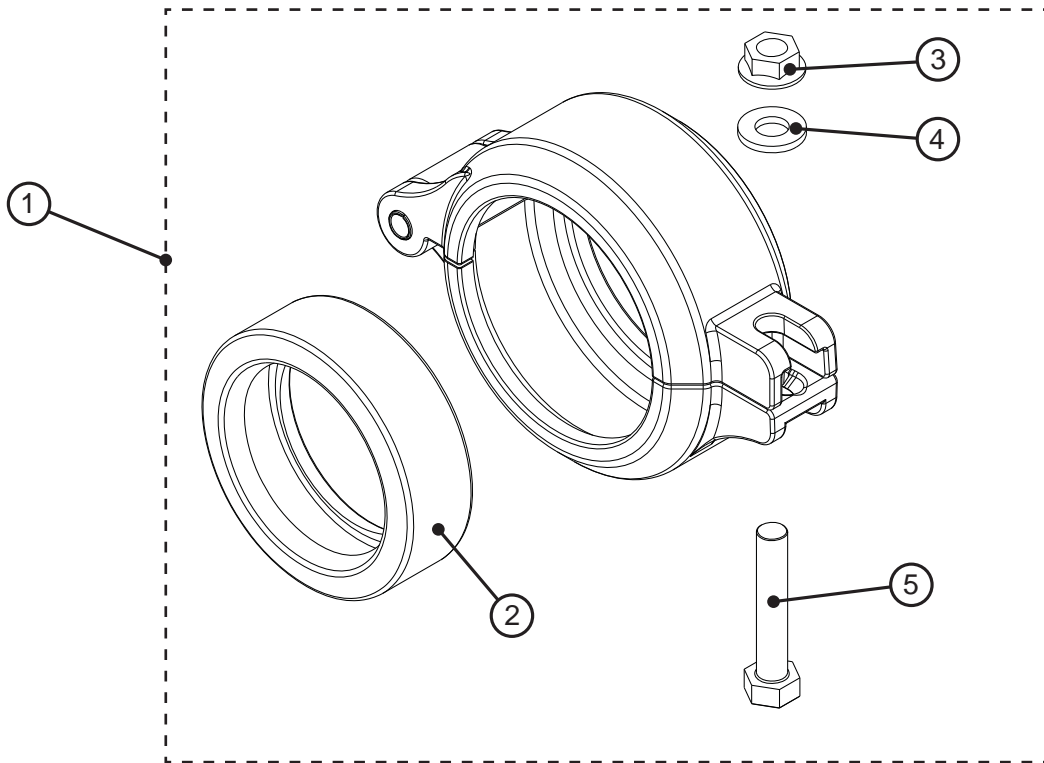

WS2H/ WS3 Error Codes

Possible Errors	
Code	Description
1001	No Encoder Pulses
1002	Unexpected Stall, Main Drive
1003	Run Time To Long, Main Drive
14001	Message Queue Full
15003	Run Time To Long, Bypass Drive
15010	Run Time To Short, Bypass Drive Could Not Drive Offline
15011	Run Time To Short, Bypass Drive Could Not Drive Online
16001	Communication Lost With Unit 2
16002	Communication Lost With Unit 3
16003	Communication Lost With Unit 4
16004	Regen List Full
17000	Run Time To Long, Separate Source Drive
17002	Run Time To Short, Separate Source Drive
18000	Reset Performed
18001	Power Loss
18002	Power Restored

WS2H/ WS3 Trouble Shooting Guide

Problem	Possible Cause	Solution
1. No Display on POD	<ul style="list-style-type: none"> a. No power at electric outlet b. Control valve Power Adapter not plugged into outlet or power cord end not connected to PC board connection c. Improper power supply d. Poor connection between POD connector and PC Board. e. Defective Power Adapter f. Defective PC Board 	<ul style="list-style-type: none"> a. Repair outlet or use working outlet b. Plug Power Adapter into outlet or connect power cord end to PC Board connection c. Verify proper voltage is being delivered to PC Board d. Check connector on POD, possible broken wire or terminal pin not inserted properly in connector. Clean pins on PC Board by plugging & unplugging the POD connector a few times to remove excess protective coating. e. Replace Power Adapter f. Replace PC Board
2. POD does not display correct time of day	<ul style="list-style-type: none"> a. Power Adapter plugged into electric outlet controlled by light switch b. Tripped breaker switch and/or tripped GFI c. Power outage d. Defective PC Board 	<ul style="list-style-type: none"> a. Use uninterrupted outlet b. Reset breaker switch and/ or GFI switch c. Reset time of day d. Replace PC Board
3. Display does not indicate that water is flowing. Refer to user instructions for how the display indicates water is flowing	<ul style="list-style-type: none"> a. Bypass/ isolation valve in bypass position b. Meter is not connected to meter connection on PC Board c. Restricted/ stalled meter turbine d. Meter wire not installed securely into three pin connector e. Defective meter f. Defective PC Board 	<ul style="list-style-type: none"> a. Turn bypass/ isolation handles to place in service position b. Connect meter to three pin connection labeled FLOW on PC Board c. Remove meter and check for rotation or foreign material d. Verify meter cable wires are installed securely into three pin connector labeled FLOW e. Replace meter f. Replace PC Board
4. Control valve regenerates at wrong time of day	<ul style="list-style-type: none"> a. Power outage b. Time of day not set correctly c. Time of regeneration set incorrectly d. Control valve set at “on 0” (immediate regeneration) 	<ul style="list-style-type: none"> a. Reset time of day. b. Reset to correct time of day c. Reset regeneration time d. Check programming setting and reset to dEL (for a delayed regen time)
5. Time of day flashes on and off	<ul style="list-style-type: none"> a. Power outage 	<ul style="list-style-type: none"> a. Reset time of day.
6. Control valve does not regenerate automatically when the REGEN button is depressed and held.	<ul style="list-style-type: none"> a. Defective PC Board b. For the case of systems, another unit in regen would not allow another unit to go into regeneration. 	<ul style="list-style-type: none"> a. Replace PC Board b. Wait for unit in regeneration to finish

Problem	Possible Cause	Solution
<p>7. Control valve does not regenerate automatically but does when the REGEN button is depressed and held.</p>	<ul style="list-style-type: none"> a. Bypass/ isolation valves in bypass position b. Meter is not connected to meter connection on PC Board c. Restricted/ stalled meter turbine d. Incorrect programming e. Meter wire not installed securely into three pin connector f. Defective meter g. Defective PC Board 	<ul style="list-style-type: none"> a. Turn bypass/ isolation valves handles to place in service position b. Connect meter to three pin connection labeled FLOW on PC Board c. Remove meter and check for rotation or foreign material d. Check for programming error e. Verify meter cable wires are installed securely into three pin connector labeled FLOW f. Replace meter g. Replace PC Board
<p>8. Hard or untreated water is being delivered</p>	<p>Check water quality directly at unit outlet</p> <ul style="list-style-type: none"> 1) Water quality is good <ul style="list-style-type: none"> a) Bypass/ isolation valves are open or faulty 2) Water quality is poor <ul style="list-style-type: none"> a) Damaged seal/stack assembly b) Faulty riser tube or seal c) Control valve body type and piston type mix matched 3) Media is exhausted, water quality is poor <ul style="list-style-type: none"> a) Higher than anticipated water usage b) Meter not registering c) No regenerant or low level of regenerant in regenerant tank d) Control fails to draw in regenerant e) Water quality fluctuation f) Fouled media bed 	<ul style="list-style-type: none"> 1) External Bypass Leak <ul style="list-style-type: none"> a) Fully close bypass/ isolation valves or replace 2) Internal Bypass Leak <ul style="list-style-type: none"> a) Replace seal/stack assembly b) Verify seal placement & engagement with riser c) Verify proper control valve body type and piston type match 3) No internal leaks <ul style="list-style-type: none"> a) Check program settings or diagnostics for abnormal water usage b) See Troubleshooting Guide #3 c) Check refill setting in programming. Check refill flow control for restrictions or debris and clean or replace, check refill flow control rate for proper fill time. d) Refer to Troubleshooting Guide # 12 e) Test water and adjust program values accordingly f) Replace media bed
<p>9. Control valve uses too much regenerant</p>	<ul style="list-style-type: none"> a. Improper refill setting or refill fill flow control is not sized properly b. Improper program settings c. Control valve regenerates frequently 	<ul style="list-style-type: none"> a. Check refill setting and check refill flow control for proper refill rate. b. Check program setting to make sure they are specific to the water quality and application needs c. Check for leaking fixtures that may be exhausting capacity or system is undersized

Problem	Possible Cause	Solution
10. Residual regenerant being delivered to service	<ul style="list-style-type: none"> a. Low water pressure b. Plugged, fouled, or incorrect injector size c. Restricted drain line d. Damaged seal/ stack assembly or piston allowing leakage during draw e. Draw time too short f. Excessive refill g. Vacuum leak in draw line / elbow 	<ul style="list-style-type: none"> a. Check incoming water pressure – water pressure must remain at minimum of 25 psi b. Inspect and clean or replace injector, or replace injector with correct size for the application c. Check drain line for restrictions or debris and clean d. Check seal/ stack assembly and piston for damage and replace e. Program proper draw time needed f. Program proper refill time needed g. Locate vacuum leak and fix
11. Excessive water in regenerant tank	<ul style="list-style-type: none"> 1) Tank is being overfilled <ul style="list-style-type: none"> a) Improper program settings b) Missing refill flow controller 2) Previous regenerant is not being drawn out 	<ul style="list-style-type: none"> 1) Excess from fill cycle <ul style="list-style-type: none"> a) Verify program settings b) Visual inspection / measure volume output into container 2) See Troubleshooting Guide #12
12. Control valve fails to draw in regenerant	<ul style="list-style-type: none"> a. Injector is plugged b. Faulty regenerant piston c. Regenerant line connection leak d. Drain line restriction or debris cause excess back pressure e. Drain line too long or too high f. Low water pressure g. Damaged seal/ stack assembly 	<ul style="list-style-type: none"> a. Remove injector and clean or replace b. Replace regenerant piston c. Inspect regenerant line for air leak d. Inspect drain line and clean to correct restriction e. Shorten length and/or height f. Check incoming water pressure – water pressure must remain at minimum of 25 psi g. Inspect seal stack assembly for damage and replace
13. Water running to drain	<ul style="list-style-type: none"> a. Power outage during regeneration or unit is currently in regeneration b. Damaged seal/ stack assembly c. Piston assembly failure d. Drive cap assembly not tightened properly 	<ul style="list-style-type: none"> a. Upon power being restored control will finish the remaining regeneration time. Reset time of day. b. Replace seal/ stack assembly c. Replace piston assembly d. Re-tighten the drive cap assembly
14. Motor drives intermittently during regeneration.	<ul style="list-style-type: none"> a. Low power 	<ul style="list-style-type: none"> a. See Table 2 Software and Power Supply Compatibility

Problem	Possible Cause	Solution
15. Err – 1001 = Control unable to sense motor movement	<ul style="list-style-type: none"> a. Motor not inserted fully to engage pinion, motor wires broken or disconnected b. PC Board not properly snapped into drive bracket c. Missing reduction gears d. Damaged or dirty reduction gear reflectors e. Faulty or dirty optics on back of PC board 	<ul style="list-style-type: none"> a. Disconnect power, make sure motor is fully engaged, check for broken wires, make sure two pin connector on motor is connected to the two pin connection on the PC Board labeled REGEN. Press NEXT and REGEN buttons for about 3 seconds to resynchronize software with piston position. b. Properly snap PC Board into drive bracket and then Press NEXT and REGEN buttons for about 3 seconds to resynchronize software with piston position. c. Replace missing gears d. Clean or replace reduction gear e. Clean or replace PC Board
16. Err – 1002 = Control valve motor ran too short and was unable to find the next cycle position and stalled	<ul style="list-style-type: none"> a. Foreign material is lodged in control valve b. Mechanical binding c. Main drive gear too tight d. Improper voltage being delivered to PC Board 	<ul style="list-style-type: none"> a. Open up control valve and pull out piston assembly and seal/ stack assembly for inspection. Press NEXT and REGEN buttons for about 3 seconds to resynchronize software with piston position. b. Check piston and seal/ stack assembly, check reduction gears, check drive bracket and main drive gear interface. Press NEXT and REGEN buttons for about 3 seconds to resynchronize software with piston position. Check that pinion is not pressed up tight against motor c. Loosen main drive gear. Press NEXT and REGEN buttons for about 3 seconds to resynchronize software with piston position. Verify free motion by rotating main drive gear by hand, driving piston in and out d. Verify that proper voltage is being supplied. Press NEXT and REGEN buttons for about 3 seconds to resynchronize software with piston position.

Problem	Possible Cause	Solution
<p>17. Err – 1003 = Control valve motor ran too long and was unable to find the next cycle position</p>	<p>a. Motor failure during a regeneration</p> <p>b. Foreign matter built up on piston and stack assemblies creating friction and drag enough to time out motor</p> <p>c. Drive bracket not snapped in properly and out of position enough that reduction gears and drive gear do not interface</p> <p>d. Low voltage slowing drive</p>	<p>a. Check motor connections then Press NEXT and REGEN buttons for about 3 seconds to resynchronize software with piston position.</p> <p>b. Replace piston and stack assemblies. Press NEXT and REGEN buttons for about 3 seconds to resynchronize software with piston position.</p> <p>c. Snap drive bracket in properly then press NEXT and REGEN buttons for about 3 seconds to resynchronize software with piston position.</p> <p>d. See Table 2 Software and Power Supply Compatibility</p>
<p>18. Err - 14001 = Message queue full</p>	<p>a. Master PC Board did not receive a response from slave units.</p>	<p>a. Press NEXT and REGEN buttons for about 3 seconds to resynchronize software with piston position.</p>
<p>19. Err -15003 = Motorized Bypass or MAV for NHBP valve motor ran too long and unable to find the proper park position</p> <p>Motorized Alternating Valve = MAV</p> <p>No Hard Water Bypass = NHBP</p>	<p>a. Control valve programmed for ALT A or noHbP without having a motorized drive securely connected to the 2 pin terminal labeled “BYPASS” on the main PC Board</p> <p>b. Poor wire connection</p> <p>c. Excess drag causing timeout before stall</p> <p>d. Motorized Bypass or MAV for NHBP motor not fully engaged with reduction gears</p>	<p>a. Press NEXT and REGEN buttons for about 3 seconds to resynchronize software with piston position. Then re-program valve to proper setting</p> <p>b. Remove power and check connection for Motorized Bypass or MAV for NHBP motor to PC Board two pin connection labeled BYPASS. Make sure wires in connector are inserted securely and no wires are broken. Clean pins on PC Board by plugging and unplugging the connector a few times to remove excess protective coating. Press NEXT and REGEN buttons for about 3 seconds to resynchronize software with piston position.</p> <p>c. Open up Motorized Bypass or MAV for NHBP to check for obstructions</p> <p>d. Properly insert motor into casing, do not force into casing. Press NEXT and REGEN buttons for about 3 seconds to resynchronize software with piston position.</p>

Problem	Possible Cause	Solution
<p>20. Err – 15010 = Motorized Bypass or MAV for NHBP valve motor ran too short (stalled) while trying to drive off-line</p> <p>Motorized Alternating Valve = MAV</p> <p>No Hard Water Bypass = NHBP</p>	<p>a. Foreign material is lodged in Motorized Bypass or MAV for NHBP valve</p> <p>b. Mechanical binding</p>	<p>a. Open up Motorized Bypass or MAV for NHBP and check for foreign material. Press NEXT and REGEN buttons for about 3 seconds to resynchronize software with piston position.</p> <p>b. Check poppet drive assembly or piston and seal/ stack assembly, check reduction gears, drive gear interface, and check Motorized Bypass or MAV for NHBP black drive pinion on motor. Press NEXT and REGEN buttons for about 3 seconds to resynchronize software with piston position.</p>
<p>21. Err – 15011 = Motorized Bypass or MAV for NHBP valve motor ran too short (stalled) while trying to drive on-line</p> <p>Motorized Alternating Valve = MAV</p> <p>No Hard Water Bypass = NHBP</p>	<p>a. Foreign material is lodged in Motorized Bypass or MAV for NHBP valve</p> <p>b. Mechanical binding</p>	<p>a. Open up Motorized Bypass or MAV for NHBP and check for foreign material. Press NEXT and REGEN buttons for about 3 seconds to resynchronize software with piston position.</p> <p>b. Check poppet drive assembly or piston and seal/ stack assembly, check reduction gears, drive gear interface, and check Motorized Bypass or MAV for NHBP black drive pinion on motor. Press NEXT and REGEN buttons for about 3 seconds to resynchronize software with piston position.</p>

Problem	Possible Cause	Solution
<p>22. # of units error: Communications has been broken with the unit specified in the error message. These errors are logged as 16K series errors as follows: 16001: error with unit 2 16002: error with unit 3 16003: error with unit 4</p>	<p>a. System is programmed for the wrong number of units or a Slave unit is in “error # of units” mode due to loss of power.</p> <p>b. Poor connection on PC Boards</p> <p>c. More than one unit has determined that it is the master control</p>	<p>1) Correct all errors on satellite units before attempting to reset error on master</p> <p>a. Pressing any button while in the # of units error will enter the user into the setting screen. Adjust to the correct units for the system and press NEXT to exit the set up screen. Press NEXT and REGEN buttons for about 3 seconds to resynchronize software with piston position. Re-program valve to proper setting.</p> <p>b. Make sure wires in connector are inserted securely and no wires are broken. Clean pins on PC Board by plugging and unplugging the connector a few times to remove excess protective coating. Press NEXT and REGEN buttons for about 3 seconds to resynchronize software with piston position.</p> <p>c. Press NEXT and REGEN buttons for about 3 seconds to resynchronize software with piston position. Then re-program each valve to operate as single individual unit. Re-program the control that is to be the master control and it will filter down the programming to the slave controls automatically.</p>
<p>23. Err – 17000 = MAV for Separate Source valve motor ran too long while trying to find proper park position</p>	<p>a. Control valve programmed for “ON SEP In” with out having a MAV for separate source attached</p> <p>b. MAV for separate source motor wire not connected to System Board or poor connection</p> <p>c. MAV for separate source motor not fully engaged with reduction gears</p>	<p>a. Press NEXT and REGEN buttons for about 3 seconds to resynchronize software with piston position. Re-program valve to proper setting</p> <p>b. Remove power and check connection on MAV for separate source motor wire to System Board two pin connection labeled AUX DRIVE. Make sure wires in connector are inserted securely and no wires are broken. Clean pins on System Board by plugging and unplugging the connector a few times to remove excess protective coating. Press NEXT and REGEN buttons for about 3 seconds to resynchronize software with piston position.</p> <p>c. Properly insert motor into casing, do not force into casing. Press NEXT and REGEN buttons for about 3 seconds to resynchronize software with piston position.</p>

Problem	Possible Cause	Solution
24. Err – 17002 = MAV for Separate Source valve motor ran too short while trying to find proper park position	<ul style="list-style-type: none"> a. Foreign material is lodged in MAV for separate source valve b. Mechanical binding 	<ul style="list-style-type: none"> a. Open up MAV for separate source and check for foreign material. Press NEXT and REGEN buttons for about 3 seconds to resynchronize software with piston position. b. Check poppet drive assembly or piston and seal/ stack assembly, check reduction gears, drive gear interface, and check MAV for separate source black drive pinion on motor. Press NEXT and REGEN buttons for about 3 seconds to resynchronize software with piston position.
25. Err – 18000 = Reset was performed, this error code will display in the diagnostics under the error log	a. Press the NEXT and REGEN buttons for about 3 seconds to resynchronize software with piston position.	
26. Err – 18001 = Power loss, this error code will display in the diagnostics under error log	a. When power is lost a signal is sent to log the power loss	
27. Err – 18002 = Power restored, this error code will display in the diagnostics under error log	a. When power is restored a signal is sent to log the power being restored	

**Order No. V3010-2A
US Units**

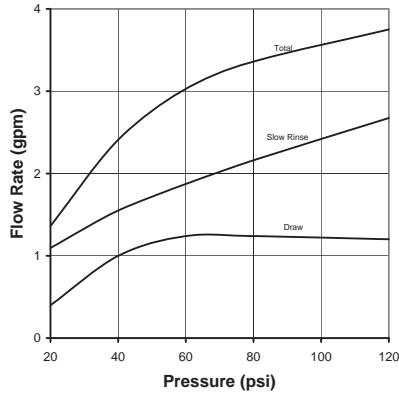

**Order No. V3010-2B
US Units**

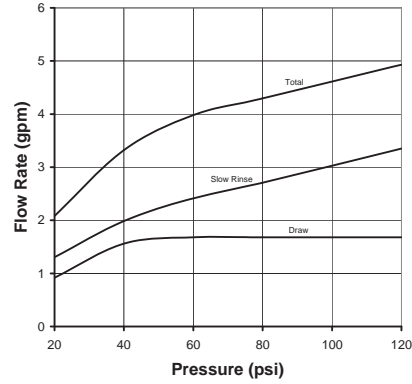

**Order No. V3010-2C
US Units**

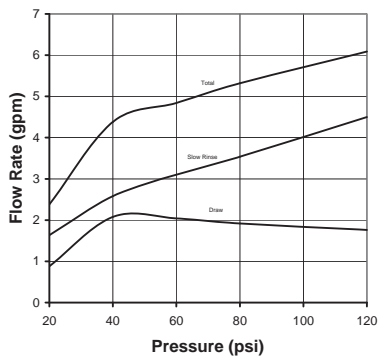

**Order No. V3010-2D
US Units**

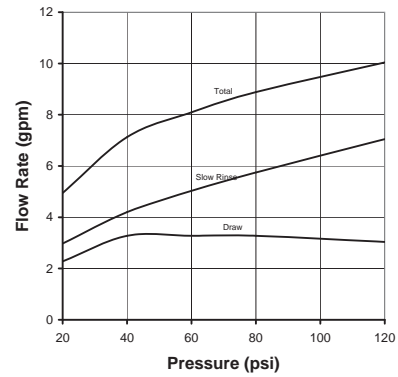

**Order No. V3010-2E
US Units**

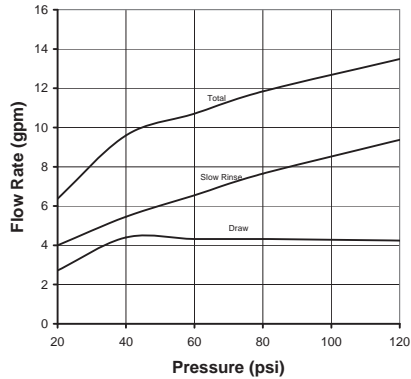

**Order No. V3010-2F
US Units**

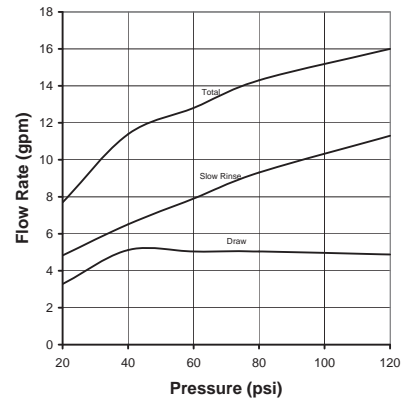

**Order No. V3010-2G
US Units**

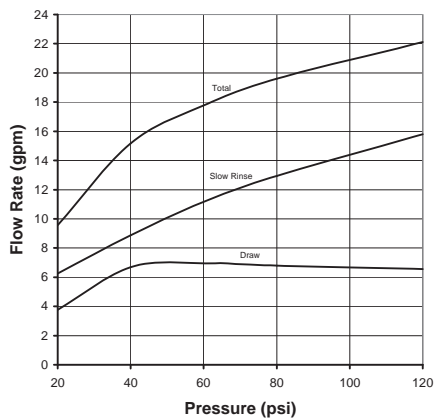

**Order No. V3010-2H
US Units**

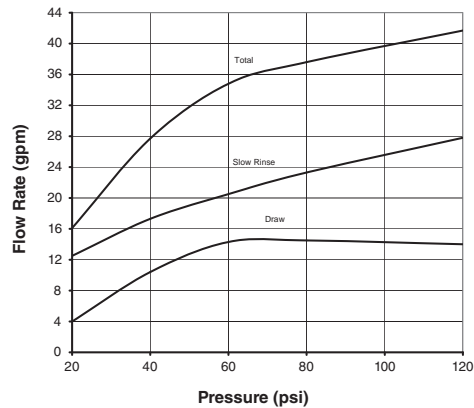

**Order No. V3010-2A
Metric Units**

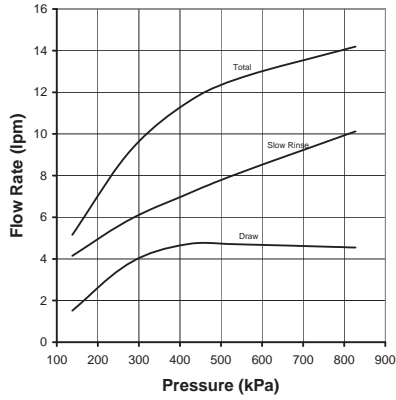

**Order No. V3010-2B
Metric Units**

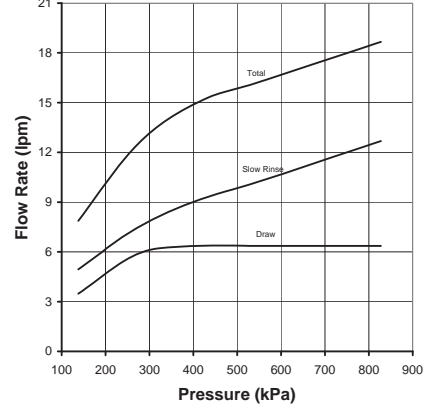

**Order No. V3010-2C
Metric Units**

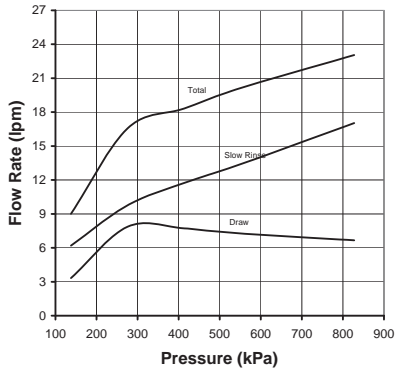

**Order No. V3010-2D
Metric Units**

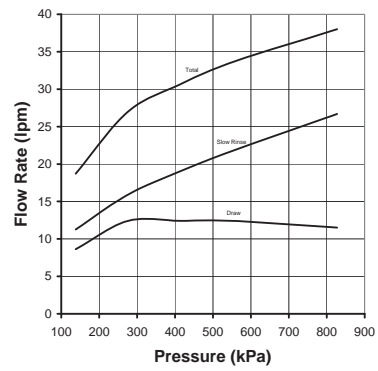

**Order No. V3010-2E
Metric Units**

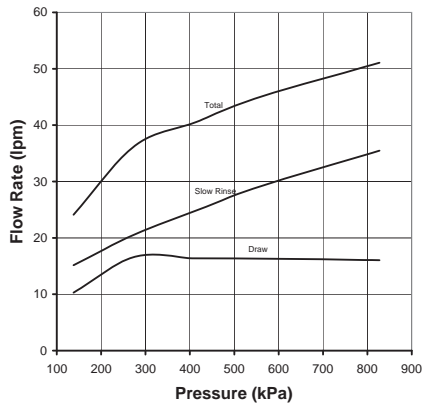

**Order No. V3010-2F
Metric Units**

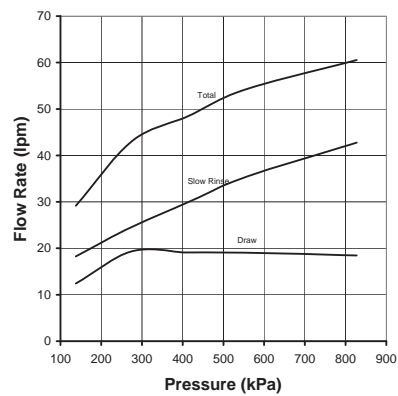

**Order No. V3010-2G
Metric Units**

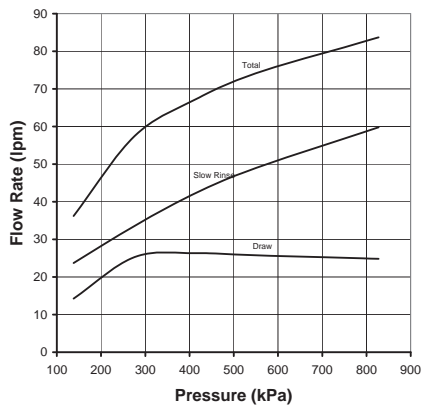

**Order No. V3010-2H
Metric Units**

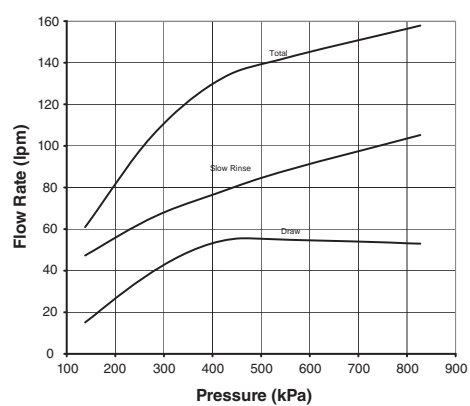

Revision History:**3/25/2010****PAGE 15:**

Not Shown	V3461	WS2H/3 AC ADAPTER	1
Not Shown	V3461EU	WS2H/3 AC ADAPTER EU	
Not Shown	V3461UK	WS2H/3 AC ADAPTER UK	

6/10/2010**PAGE 4:**

Table 1

Output Voltage 20V or 24V AC see Table 2

PAGE 5:

Added Table 2

PAGE 16:

Revised table

V3461 WS2H/3 AC ADAPTER (shipped less cord) 1

V3461EU WS2H/3 AC ADAPTER EU

7/28/2010**PAGE 16:**

6	V3107-01	WS1 MOTOR ASY	1
---	----------	---------------	---