

# TOP MOUNT 6 LATERAL (Φ53MM) DISTRIBUTOR (18" ~ 36" TANKS) QUICK CONNECTION SLOT: 0.2mm

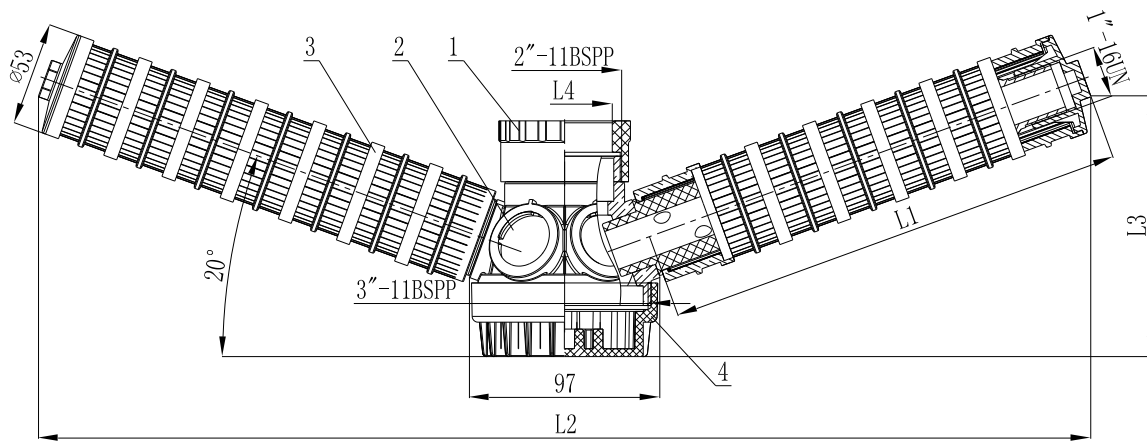

REMARK: 1PSI=0.007MPa, 1GPM=227L/H

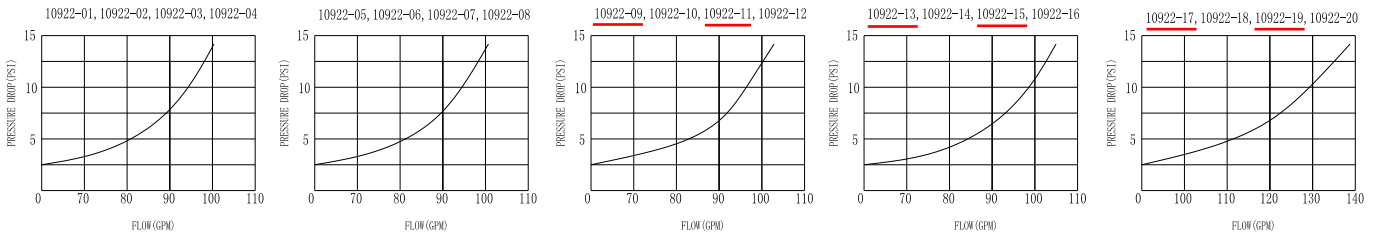

## CHART 1- COMPONENTS

ITEM	PART NUMBER	DESCRIPTION	QTY
1	SEE CHART 3	ADAPTER	1
2	50172	HUB	1
3	SEE CHART 2	Φ53 LATERAL ASSEMBLY	6
4	50235	BOTTOM CAP	1
TOOL	50177	SPLINE	1

## CHART 2 –Φ53MM LATERAL PART NUMBERS

SLOT SIZE	PART NUMBER	L1(MM)	L2(MM)	L3(MM)	TANK DIAMETER (INCHES/MM)
0.2MM	10924	143	365	103	18"(486MM)
0.2MM	10934	175	425	114	21"(555MM)
0.2MM	10935	239	545	136	24"(624MM)
0.2MM	10936	303	666	158	30"(779MM)
0.2MM	10937	367	786	180	36"(931MM)

1.5" & 2" Top Mount Hub/Lateral  
4" Threaded Tank

Item #	Tank Size	Distributor Size	Order P/N
10922-09	24"	1.5"	TAD24TM15
10922-11	24"	2"	TAD24TM20
10922-13	30"	1.5"	TAD30TM15
10922-15	30"	2"	TAD30TM20
10922-17	36"	1.5"	TAD36TM15
10922-19	36"	2"	TAD36TM20



# TOP MOUNT 6 LATERAL (Φ35MM) DISTRIBUTOR (12" ~ 21" TANKS) QUICK CONNECTION SLOT: 0.2mm



REMARK: 1PSI=0.007MPa, 1GPM=227L/H

10920-03, 10920-04, 10920-05, 10920-06

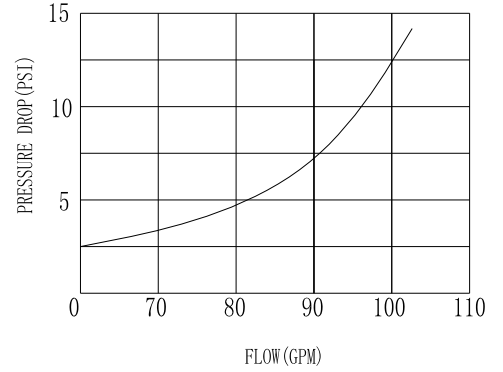
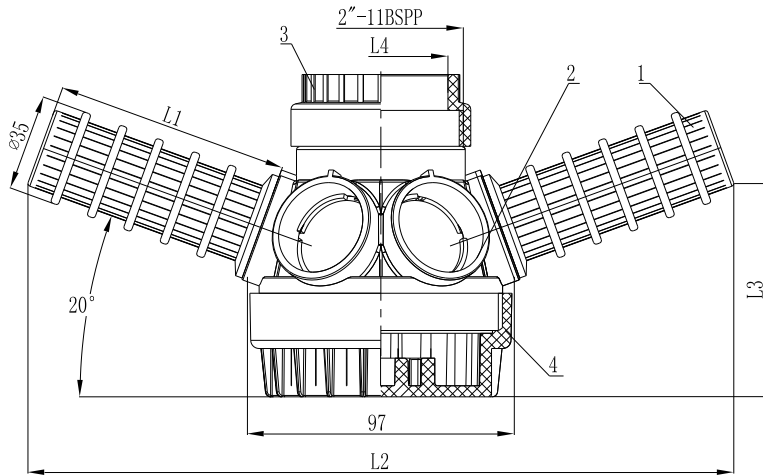

10920-07, 10920-08, 10920-09, 10920-10

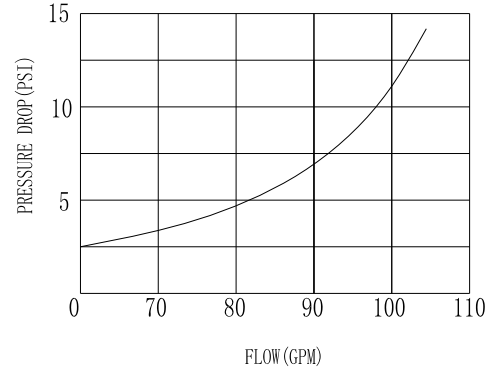

## CHART 1- COMPONENTS

ITEM	PART NUMBER	DESCRIPTION	QTY
1	SEE CHART 2	Φ35 LATERAL	6
2	50172	HUB	1
3	SEE CHART 3	ADAPTER	1
4	50235	BOTTOM CAP	1
TOOL	50177	SPLINE	1

## CHART 2 –Φ35MM LATERAL PART NUMBERS

PART NUMBER	L1(MM)	L2(MM)	L3(MM)	TANK DIAMETER (INCHES/MM)
50168	100	281	82	12"(310MM)
50169	114	307	87	13" AND 14" (336MM~363MM)
50170	142	360	96	16"(413MM)
50171	184	439	110	18" AND 21"(486~555MM)

## CHART 3 – ADAPTER PART NUMBERS

PART NUMBER	CENTRAL PIPE DIAMETER	L4(MM)
50174	1.5" PIPE ( 1.901" O.D. ) (SOCKET FIT)	48.5
50175	50 MM O.D. PIPE (SOCKET FIT)	50

1.5" Top Mount Hub/Lateral  
4" Threaded Tank

Item #  
10920-05  
10920-07  
10920-09

Tank Size  
13" & 14"  
16"  
18" & 21"

Order P/N  
TAD14TM15  
TAD16TM15  
TAD18/21TM15



**TOP MOUNT 6 LATERAL (Φ35MM) DISTRIBUTOR  
(12" ~ 21" TANKS) QUICK CONNECTION  
SLOT: 0. 2mm**



**CHART 4 – COMPLETE ASSEMBLY PART NUMBERS (0.2MM SLOT)**

ASSEMBLY PART NUMBER	TANK DIAMETER(INCHES)	Φ35 LATERAL PART NUMBER	ADAPTER PART NUMBER
10920-03	12"	50168	50174-E
10920-04	12"	50168	50175-M
10920-05	13"/14"	50169	50174-E
10920-06	13"/14"	50169	50175-M
10920-07	16"	50170	50174-E
10920-08	16"	50170	50175-M
10920-09	18"/21"	50171	50174-E
10920-10	18"/21"	50171	50175-M

**TOP MOUNT 6 LATERAL (Φ53MM) DISTRIBUTOR  
(18" ~ 36" TANKS) QUICK CONNECTION  
SLOT: 0.2mm**



**CHART 3 – ADAPTER PART NUMBERS**

PART NUMBER	CENTRAL PIPE DIAMETER	L4(MM)
50174	1.5"PIPE (1.901"O.D.) (SOCKET FIT)	48.5
50175	50MM O.D. PIPE (SOCKET FIT)	50
10726	2"PIPE (2.374"O.D.) (SOCKET FIT)	60.3
10727	63MM O.D. PIPE (SOCKET FIT)	63

**CHART 4 – COMPLETE ASSEMBLY PART NUMBERS (0.2MM SLOT)**

ASSEMBLY PART NUMBER	TANK DIAMETER (INCHES)	Φ53 LATERAL ASSEMBLY PART NUMBER	ADAPTER PART NUMBER
10922-01	18"	10924	50174-E
10922-02	18"	10924	50175-M
10922-03	18"	10924	10726-E
10922-04	18"	10924	10727-M
10922-05	21"	10934	50174-E
10922-06	21"	10934	50175-M
10922-07	21"	10934	10726-E
10922-08	21"	10934	10727-M
10922-09	24"	10935	50174-E
10922-10	24"	10935	50175-M
10922-11	24"	10935	10726-E
10922-12	24"	10935	10727-M
10922-13	30"	10936	50174-E
10922-14	30"	10936	50175-M
10922-15	30"	10936	10726-E
10922-16	30"	10936	10727-M
10922-17	36"	10937	50174-E
10922-18	36"	10937	50175-M
10922-19	36"	10937	10726-E
10922-20	36"	10937	10727-M



# BOTTOM MOUNT 6 LATERAL (Φ53MM) DISTRIBUTOR (18" ~ 36" TANKS) QUICK CONNECTION

SLOT: 0.2mm

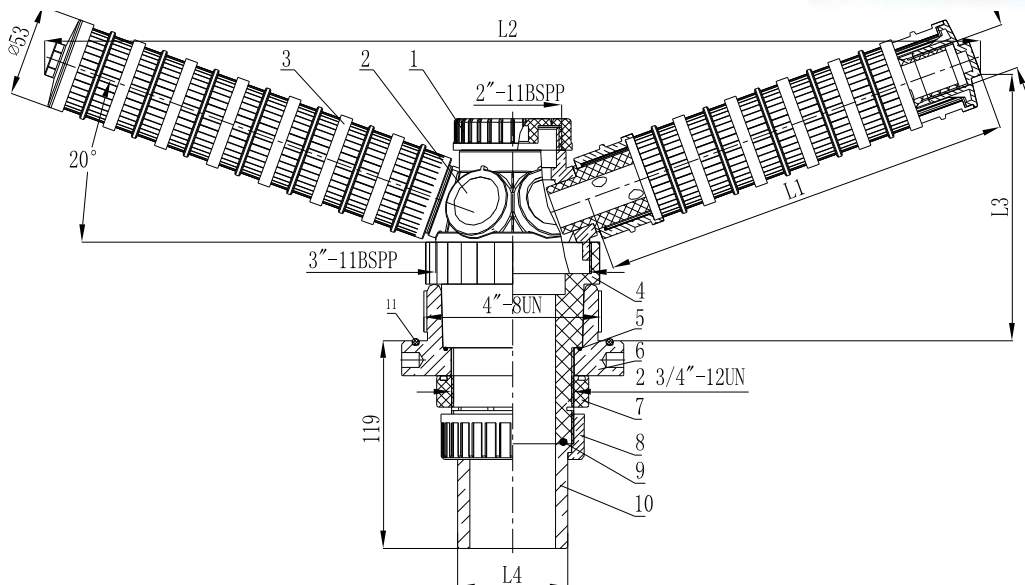

REMARK: 1PSI=0.007MPa, 1GPM=227L/H

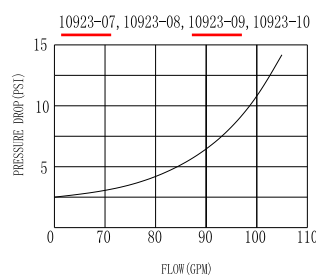
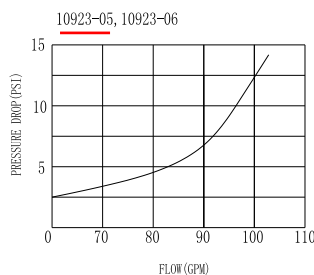
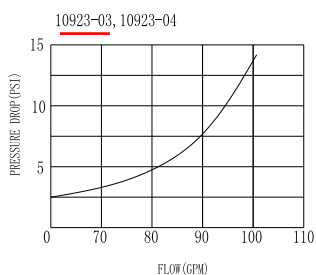
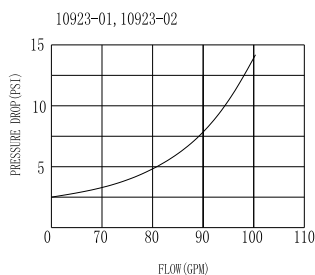

## CHART 1- COMPONENTS

ITEM	PART NUMBER	DESCRIPTION	QTY
1	50176	TOP CAP	1
2	50172	HUB	1
3	SEE CHART 2	Φ53 LATERAL ASSEMBLY	6
4	50238	TUBE	1
5	10833	O RING	1
6	11017	4" ADAPTER	1
7	50179	NUT	1
8	10715	UNION	1
9	10834	O RING	1
10	SEE CHART 3	JOINT	1
11	10229	O RING	1
TOOL	50177	SPLINE	1

2" Bottom Mount Hub/Lateral  
4" Threaded Tank

Item #

10923-03

10923-05

10923-07

10923-09

Tank Size

21"

24"

30"

36"

Order P/N

TAD21BM20

TAD24BM20

TAD30BM20

TAD36BM20



**BOTTOM MOUNT 6 LATERAL (Φ53MM) DISTRIBUTOR  
(18" ~ 36" TANKS) QUICK CONNECTION  
SLOT: 0.2mm**



**CHART 2 –Φ53MM LATERAL PART NUMBERS**

SLOT SIZE	PART NUMBER	L1(MM)	L2(MM)	L3(MM)	TANK DIAMETER (INCHES/MM)
0.2MM	10924	143	365	103	18"(486MM)
0.2MM	10934	175	425	114	21"(555MM)
0.2MM	10935	239	545	136	24"(624MM)
0.2MM	10936	303	666	158	30"(779MM)
0.2MM	10937	367	786	180	36"(931MM)

**CHART 3 – ADAPTER PART NUMBERS**

PART NUMBER	JOINT DIAMETER	L4(MM)
10716	2"(2.374"O.D.) (SOCKET FIT)	60.3
10717	63MM O.D. (SOCKET FIT)	63

**CHART 4 – COMPLETE ASSEMBLY PART NUMBERS (0.2MM SLOT)**

ASSEMBLY PART NUMBER	TANK DIAMETER(INCHES)	Φ53 LATERAL PART NUMBER	JOINT PART NUMBER
10923-01	18"	10924	10716-E
10923-02	18"	10924	10717-M
10923-03	21"	10934	10716-E
10923-04	21"	10934	10717-M
10923-05	24"	10935	10716E
10923-06	24"	10935	10717-M
10923-07	30"	10936	10716-E
10923-08	30"	10936	10717-M
10923-09	36"	10937	10716-E
10923-10	36"	10937	10717-M

# TOP MOUNT 2.5" DIFFUSER DISTRIBUTOR (12" ~ 36" TANKS)

SLOT: 0.2mm-Black Color AND 0.5mm-Grey Color



**CHART 1- COMPONENTS**

ITEM	PART NUMBER	DESCRIPTION	QTY
1	50183	CAP	1
2	50184	BASE	1
3	50181	SHELF	1
4	50182	0.2MM SLICE OR	45
	50258	0.5MM SLICE	43
5	10728	ADAPTER	1
6	50178	TUBE	1
7	10833	O RING	1
8	11017	4" ADAPTER	1
9	50179	NUT	1
10	10715	UNION	1
11	10834	O RING	1
12	SEE CHART 2	JOINT	1
13	10229	O RING	1

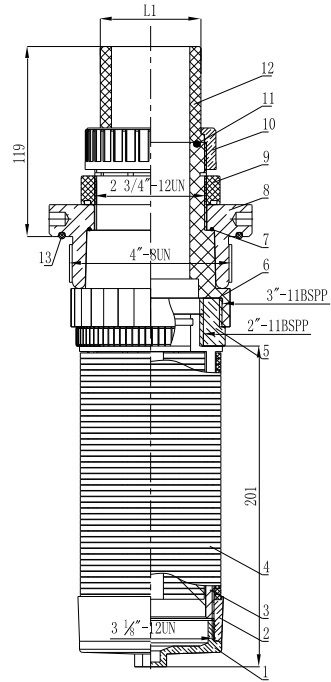

REMARK: 1PSI=0.007MPa, 1GPM=227L/H

(——) 0.2mm Slot  
(- - -) 0.5mm Slot

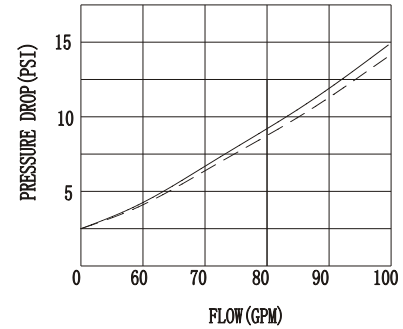

**CHART 2-JOINT PART NUMBERS**

PART NUMBER	JOINT DIAMETER	L1(MM)
10716	2"(2.374"O.D.)	60.3
10717	63MM O.D.	63

**CHART 3- COMPLETE ASSEMBLY PART NUMBERS (0.2MM SLOT)**

ASSEMBLY PART NUMBER	TANK DIAMETER(INCHES)	JOINT PART NUMBER
<u>10932</u>	12"~36"	10716-E
11250	12"~36"	10717-M

**CHART 4- COMPLETE ASSEMBLY PART NUMBERS (0.5MM SLOT)**

ASSEMBLY PART NUMBER	TANK DIAMETER(INCHES)	JOINT PART NUMBER
10932-01	12"~36"	10716-E
11250-01	12"~36"	10717-M

2" Top Mount Diffuser  
4" Threaded Tank

Item #  
10932

Tank Size  
12" to 36"

Order P/N  
TADDSF20



# BOTTOM MOUNT 16 LATERAL (Φ53MM) DISTRIBUTOR (42" ~ 63" TANKS) QUICK CONNECTION SLOT: 0.2mm

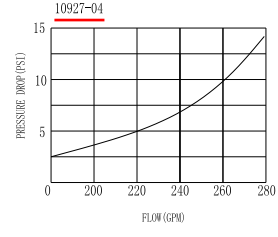
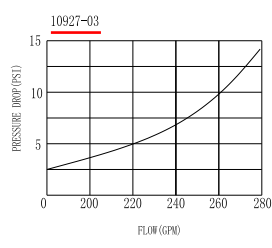
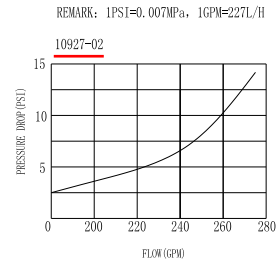
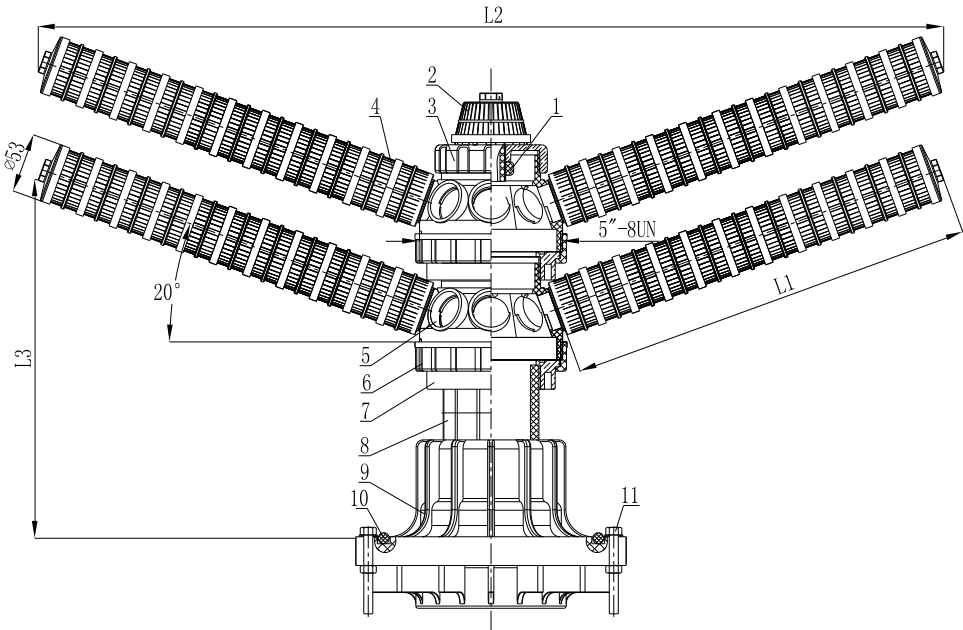

**CHART 1- COMPONENTS**

ITEM	PART NUMBER	DESCRIPTION	QTY
1	50195	NUT	1
2	10925	FILTER NOZZLE	1
3	50193	CAP	1
4	SEE CHART2	Φ53 LATERAL ASSY	16
5	50194	HUB	2
6	50197	TOP ADAPTER	2
7	50198	BOTTOM ADAPTER	2
8	50237	METRIC TUBE OR	1
	50255	ENGLISH TUBE	1
9	FLANGE KIT SOLD	FLANGE	0
10	SEPARATELY ,SEE	O RING	0
11	PAGE 39,40.	BOLT KIT	0

**CHART 2 –Φ53MM LATERAL PART NUMBERS**

SOLT SIZE	PART NUMBER	L1(MM)	L2(MM)	L3(MM)	TANK DIAMETER (INCHES/MM)
0.2MM	10938	431	939	236	42"(1089MM)
0.2MM	10939	559	1180	280	48"(1233MM)
0.2MM	10940	687	1420	324	63"(1625MM)

3" Bottom Mount High Flow  
6" Flanged Tank

Item #  
10927-02  
10927-03  
10927-04

Tank Size  
42"  
48"  
63"

Order P/N  
TAD42BMHF30  
TAD48BMHF30  
TAD63BMHF30





# BOTTOM MOUNT 8 LATERAL (Φ53MM) DISTRIBUTOR (21" ~ 63" TANKS) QUICK CONNECTION SLOT: 0.2mm

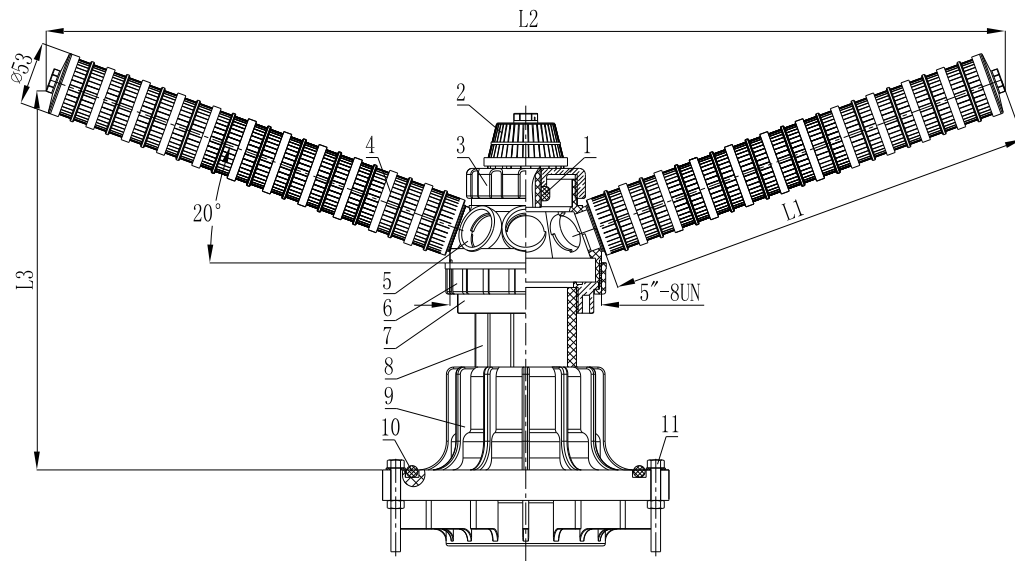

REMARK: 1PSI=0.007MPa, 1GPM=227L/H

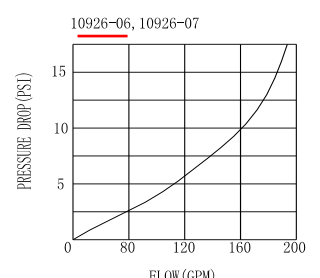
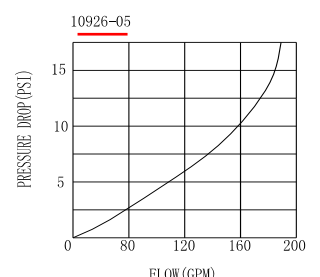
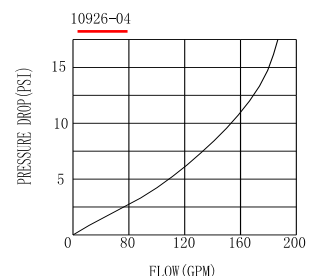
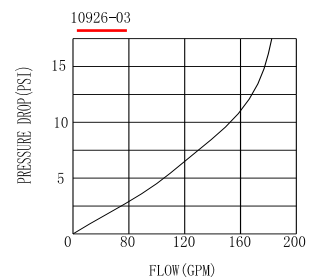
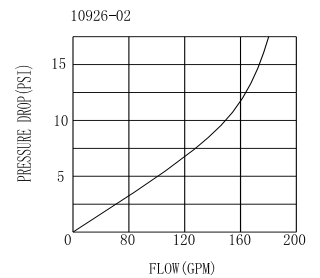
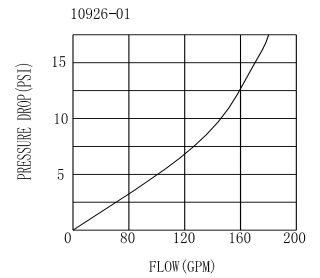

**CHART 1- COMPONENTS**

ITEM	PART NUMBER	DESCRIPTION	QTY
1	50195	NUT	1
2	10925	FILTER NOZZLE	1
3	50193	CAP	1
4	SEE CHART 2	Φ53 LATERAL ASSEMBLY	8
5	50194	HUB	1
6	50197	TOP ADAPTER	1
7	50198	BOTTOM ADAPTER	1
8	50237	METRIC TUBE OR	1
	50255	ENGLISH TUBE	1
9	FLANGE KIT SOLD	FLANGE	0
10	SEPARATELY, SEE	O RING	0
11	PAGE 39,40.	BOLT KIT	0

3" Bottom Mount Standard Flow  
6" Flanged Tank

Item #	Tank Size	Order P/N
10926-03	30"	TAD30BM30
10926-04	36"	TAD36BM30
10926-05	42"	TAD42BM30
10926-06	48"	TAD48BM30



**BOTTOM MOUNT 8 LATERAL (Φ53MM) DISTRIBUTOR  
(21" ~ 63" TANKS) QUICK CONNECTION  
SLOT: 0.2mm**



**CHART 2 –Φ53MM LATERAL PART NUMBERS**

SOLT SIZE	PART NUMBER	L1(MM)	L2(MM)	L3(MM)	TANK DIAMETER (INCHES/MM)
0.2MM	10934	175	458	148	21"(555MM)
0.2MM	10935	239	579	170	24"(624MM)
0.2MM	10936	303	699	192	30"(779MM)
0.2MM	10937	367	819	214	36"(931MM)
0.2MM	10938	431	939	236	42"(1089MM)
0.2MM	10939	559	1180	280	48"(1233MM)
0.2MM	10940	687	1420	324	63"(1625MM)

**CHART 3 – COMPLETE ASSEMBLY PART NUMBERS (0.2MM SLOT)**

**METRIC FLANGE ADAPTER 6"-3"BSPP-3"BSPP OR 6"-3"NPT-3"BSPP OR 6"-4"UN-3"BSPP**

ASSEMBLY PART NUMBER	TANK DIAMETER(INCHES)	Φ53 LATERAL PART NUMBER
10926-01	21"	10934
10926-02	24"	10935
10926-03	30"	10936
10926-04	36"	10937
10926-05	42"	10938
10926-06	48"	10939
10926-07	63"	10940

**COMPLETE ASSEMBLY PART NUMBERS (0.2MM SLOT )**

**ENGLISH FLANGE ADAPTER 6"-3"NPT-3"NPT OR 6"-4"UN-3"NPT**

ASSEMBLY PART NUMBER	TANK DIAMETER(INCHES)	Φ53 LATERAL PART NUMBER
10926-08	21"	10934
10926-09	24"	10935
10926-10	30"	10936
10926-11	36"	10937
10926-12	42"	10938
10926-13	48"	10939
10926-14	63"	10940

# TOP MOUNT 3" DIFFUSER DISTRIBUTOR HIGH FLOW (42" ~ 63" TANKS) SLOT: 0.2mm-Black Color AND 0.5mm-Grey Color

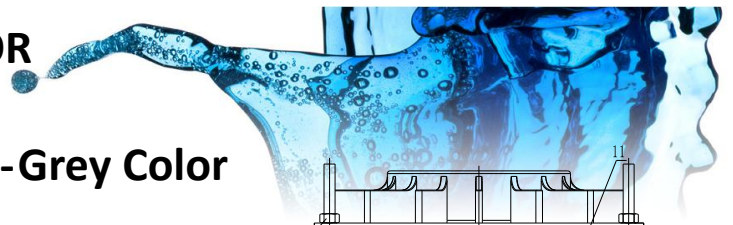

**CHART 1- COMPONENTS**

ITEM	PART NUMBER	DESCRIPTION	QTY
1	50196	METRIC TUBE OR	1
	50256	ENGLISH TUBE	1
2	50199	HUB	1
3	50195	NUT	1
4	10925	FILTER NOZZLE	1
5	50183	CAP	3
6	50184	BASE	3
7	50182	0.2MM SLICE OR	135
	50258	0.5MM SLICE	129
8	50181	SHELF	3
9	FLANGE KIT SOLD	O RING	0
10	SEPARATELY ,SEE	BOLT KIT	0
11	PAGE 39,40	FLANGE	0

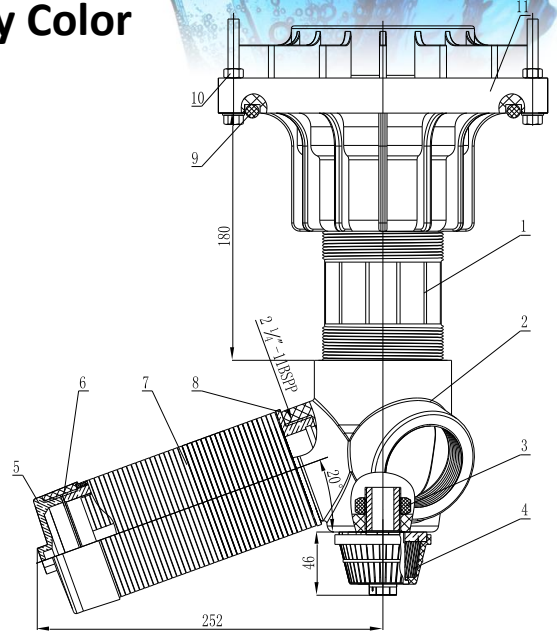

REMARK: 1PSI=0.007MPa, 1GPM=227L/H

(——) 0.2mm Slot  
(- - -) 0.5mm Slot

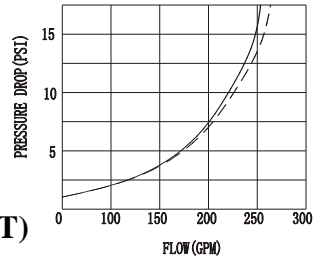

**CHART 2 – COMPLETE ASSEMBLY PART NUMBERS (0.2MM SLOT)**

**METRIC FLANGE ADAPTER 6"-3"BSPP-3"BSPP OR 6"-3"NPT-3"BSPP OR 6"-4"UN-3"BSPP**

ASSEMBLY PART NUMBER	TANK DIAMETER(INCHES)
10929	42"~63"

**ENGLISH FLANGE ADAPTER 6"-3"NPT-3"NPT OR 6"-4"UN-3"NPT**

ASSEMBLY PART NUMBER	TANK DIAMETER(INCHES)
10929-01	42"~63"

**CHART 3– COMPLETE ASSEMBLY PART NUMBERS (0.5MM SLOT)**

**METRIC FLANGE ADAPTER 6"-3"BSPP-3"BSPP OR 6"-3"NPT-3"BSPP OR 6"-4"UN-3"BSPP**

ASSEMBLY PART NUMBER	TANK DIAMETER(INCHES)
10929-02	42"~63"

**ENGLISH FLANGE ADAPTER 6"-3"NPT-3"NPT OR 6"-4"UN-3"NPT**

ASSEMBLY PART NUMBER	TANK DIAMETER(INCHES)
10929-03	42"~63"



3" Top Diffuser High Flow  
6" Flanged Tank

Item #  
10929

Tank Size  
21" to 63"

Order P/N  
TADDHF30

# TOP MOUNT 3" DIFFUSER DISTRIBUTOR HIGH FLOW (42" ~ 63" TANKS)

SLOT: 0.2mm-Black Color AND 0.5mm-Grey Color

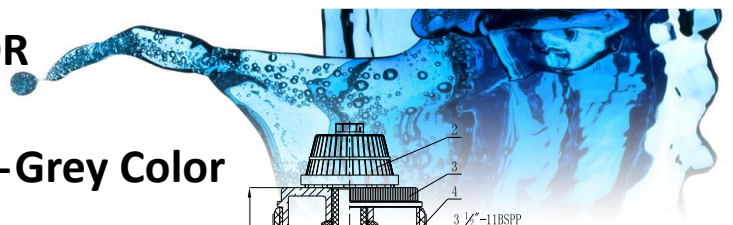

**CHART 1- COMPONENTS**

ITEM	PART NUMBER	DESCRIPTION	QTY
1	50195	NUT	1
2	10925	FILTER NOZZLE	1
3	50188	DIFFUSER CAP	1
4	10729	ADAPTER	1
5	50189	ADAPTER RING	1
6	50187	0.2MM BASKET OR	3
	50259	0.5MM BASKET	3
7	50186	METRIC BASE OR	1
	50257	ENGLISH BASE	1
8	FLANGE KIT SOLD SEPARATELY ,SEE PAGE 39,40	FLANGE	0
9		O RING	0
10		BOLT KIT	0

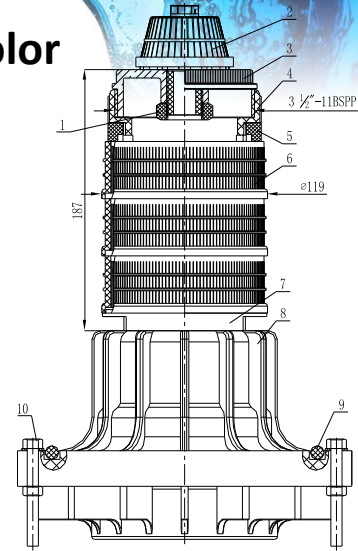

REMARK: 1PSI=0.007MPa, 1GPM=227L/H

(——) 0.2mm Slot  
(- - -) 0.5mm Slot

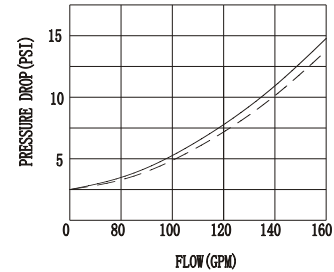

**CHART 2 – COMPLETE ASSEMBLY PART NUMBERS (0.2MM SLOT)**

**METRIC FLANGE ADAPTER 6"-3"BSPP-3"BSPP OR 6"-3"NPT-3"BSPP OR 6"-4"UN-3"BSPP**

ASSEMBLY PART NUMBER	TANK DIAMETER(INCHES)
10928	42"~63"

**ENGLISH FLANGE ADAPTER 6"-3"NPT-3"NPT OR 6"-4"UN-3"NPT**

ASSEMBLY PART NUMBER	TANK DIAMETER(INCHES)
10928-01	42"~63"

**CHART 3– COMPLETE ASSEMBLY PART NUMBERS (0.5MM SLOT)**

**METRIC FLANGE ADAPTER 6"-3"BSPP-3"BSPP OR 6"-3"NPT-3"BSPP OR 6"-4"UN-3"BSPP**

ASSEMBLY PART NUMBER	TANK DIAMETER(INCHES)
10928-02	42"~63"

**ENGLISH FLANGE ADAPTER 6"-3"NPT-3"NPT OR 6"-4"UN-3"NPT**

ASSEMBLY PART NUMBER	TANK DIAMETER(INCHES)
10928-03	42"~63"

3" Top Diffuser Standard Flow  
6" Flanged Tanks

Item #  
10928

Tank Size  
21" to 63"

Order P/N  
TADDSF30



# TOP MOUNT 8 LATERAL (Φ53MM) DISTRIBUTOR (21" ~ 63" TANKS) QUICK CONNECTION SLOT: 0.2mm

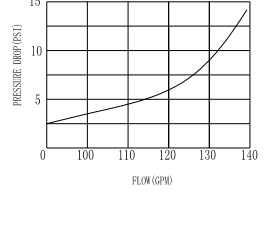
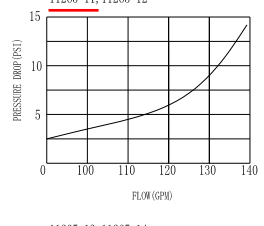
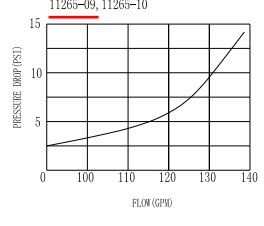
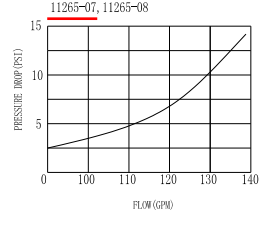
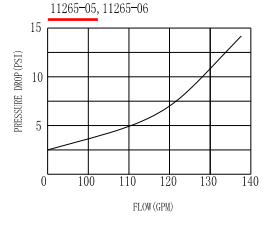
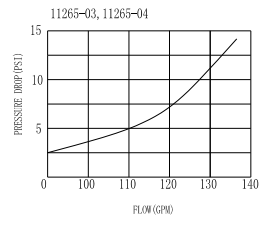
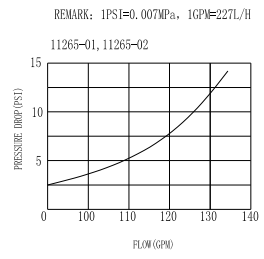
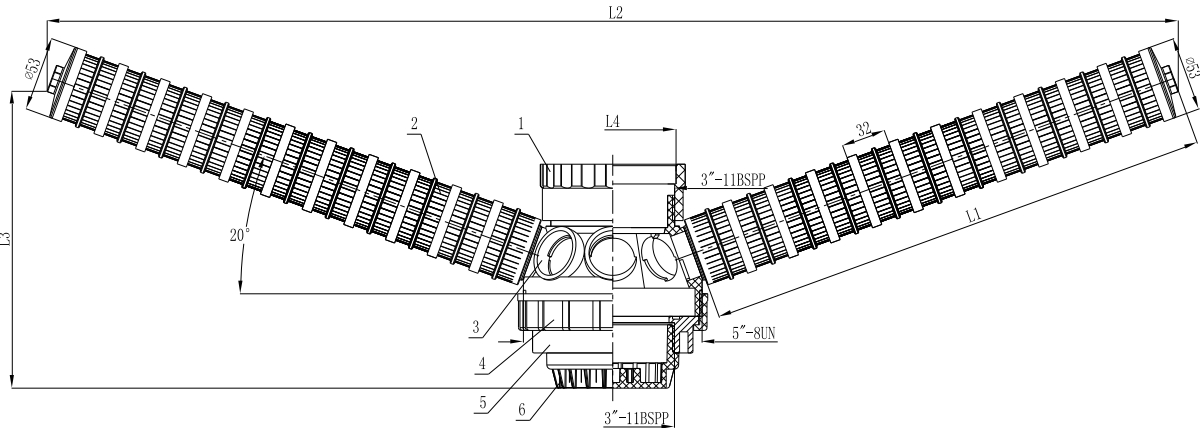

### CHART 1- COMPONENTS

ITEM	PART NUMBER	DESCRIPTION	QTY
1	SEE CHART 3	ADAPTER	1
2	SEE CHART 2	Φ53 LATERAL ASSY	8
3	50194	HUB	1
4	50197	TOP ADAPTER	1
5	50198	BOTTOM ADAPTER	1
6	50236	BOTTOM CAP	1

### CHART 2 –Φ53MM LATERAL PART NUMBERS

SOLT SIZE	PART NUMBER	L1(MM)	L2(MM)	L3(MM)	TANK DIAMETER (INCHES/MM)
0.2MM	10934	175	458	148	21"(555MM)
0.2MM	10935	239	579	170	24"(624MM)
0.2MM	10936	303	699	192	30"(779MM)
0.2MM	10937	367	819	214	36"(931MM)
0.2MM	10938	431	939	236	42"(1089MM)
0.2MM	10939	559	1180	280	48"(1233MM)
0.2MM	10940	687	1420	324	63"(1625MM)

3" Top Mount Hub/Lateral  
6" Flanged Tank

Item #	Tank Size	Order P/N
11265-05	30"	TAD30TM30
11265-07	36"	TAD36TM30
11265-09	42"	TAD42TM30
11265-11	48"	TAD48TM30



**TOP MOUNT 8 LATERAL (Φ53MM) DISTRIBUTOR  
(21" ~ 63" TANKS) QUICK CONNECTION  
SLOT: 0.2mm**

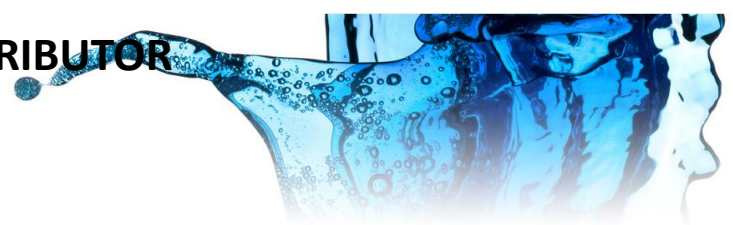

**CHART 3 – ADAPTER PART NUMBERS**

PART NUMBER	CENTRAL PIPE DIAMETER	L4(MM)
11069	3"PIPE (3.5"O.D.) (SOCKET FIT)	88.9
11070	90MM O.D. PIPE (SOCKET FIT)	90
11422	2"PIPE (2.38"O.D.) (SOCKET FIT)	60.5
11423	63MM O.D. PIPE (SOCKET FIT)	63

**CHART 4 – COMPLETE ASSEMBLY PART NUMBERS (0.2MM SLOT)**

ASSEMBLY PART NUMBER	TANK DIAMETER (INCHES)	Φ53 LATERAL PART NUMBER	ADAPTER PART NUMBER
11265-01	21"	10934	11069-E
11265-02	21"	10934	11070-M
11265-03	24"	10935	11069-E
11265-04	24"	10935	11070-M
11265-05	30"	10936	11069-E
11265-06	30"	10936	11070-M
11265-07	36"	10937	11069-E
11265-08	36"	10937	11070-M
11265-09	42"	10938	11069-E
11265-10	42"	10938	11070-M
11265-11	48"	10939	11069-E
11265-12	48"	10939	11070-M
11265-13	63"	10940	11069-E
11265-14	63"	10940	11070-M

ASSEMBLY PART NUMBER	TANK DIAMETER (INCHES)	Φ53 LATERAL PART NUMBER	ADAPTER PART NUMBER
11265-15	21"	10934	11422-E
11265-16	21"	10934	11423-M
11265-17	24"	10935	11422-E
11265-18	24"	10935	11423-M
11265-19	30"	10936	11422-E
11265-20	30"	10936	11423-M
11265-21	36"	10937	11422-E
11265-22	36"	10937	11423-M
11265-23	42"	10938	11422-E
11265-24	42"	10938	11423-M
11265-25	48"	10939	11422-E
11265-26	48"	10939	11423-M

RECOMMEND 6" FLANGE CLOSURE KITS 10584, 10585, 10916, OR 10917 ON 42"-48"-63" TANKS.

# TOP MOUNT 16 LATERAL (Φ53MM) DISTRIBUTOR HIGH FLOW (42" ~ 63" TANKS) QUICK CONNECTION SLOT: 0.2mm

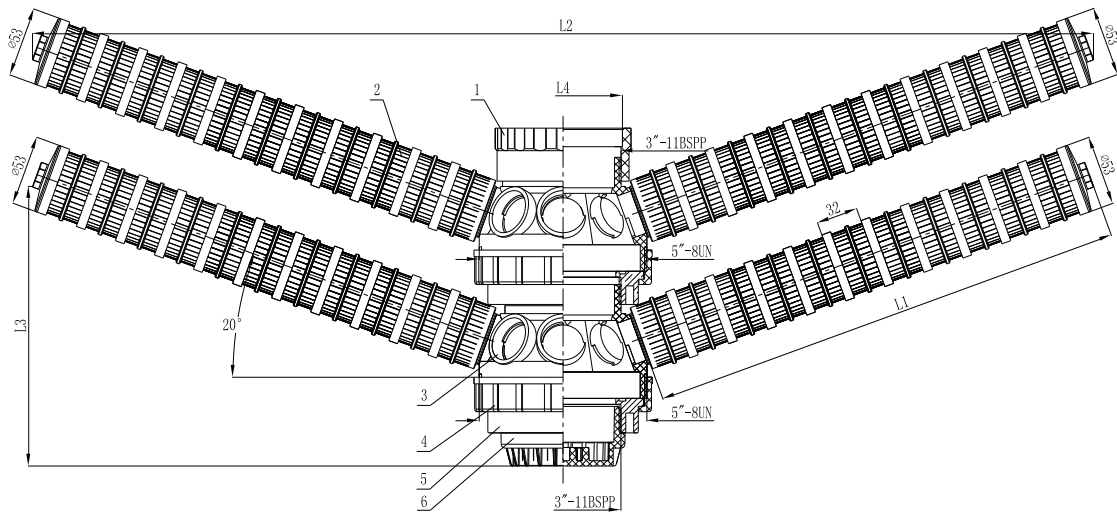

REMARK: 1PSI=0.007MPa, 1GPM=227L/H

11266-03, 11266-04

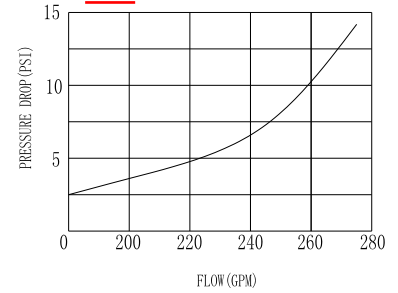

11266-05, 11266-06

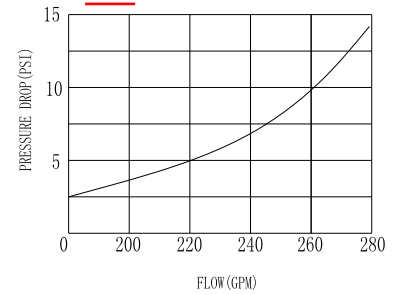

11266-07, 11266-08

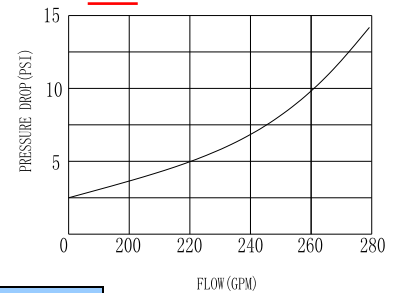

ITEM	PART NUMBER	DESCRIPTION	QTY
1	SEE CHART 3	ADAPTER	1
2	SEE CHART 2	Φ53 LATERAL ASSEMBLY	16
3	50194	HUB	2
4	50197	TOP ADAPTER	2
5	50198	BOTTOM ADAPTER	2
6	50236	BOTTOM CAP	1

## CHART 2 – Φ53MM LATERAL PART NUMBERS

SOLT SIZE	PART NUMBER	L1(MM)	L2(MM)	L3(MM)	TANK DIAMETER (INCHES/MM)
0.2MM	10938	431	939	236	42"(1089MM)
0.2MM	10939	559	1180	280	48"(1233MM)
0.2MM	10940	687	1420	324	63"(1625MM)

## CHART 3 – ADAPTER PART NUMBERS

PART NUMBER	CENTRAL PIPE DIAMETER	L4(MM)
11069	3"PIPE (3.5"O.D.) (SOCKET FIT)	88.9
11070	90MM O.D. PIPE (SOCKET FIT)	90

3" Top Mount High Flow  
6" Flanged Tank

Item #  
11266-03  
11266-05  
11266-07

Tank Size  
42"  
48"  
63"

Order P/N  
TAD42TMHF30  
TAD48TMHF30  
TAD63TMHF30



# TOP MOUNT 16 LATERAL (Φ53MM) DISTRIBUTOR HIGH FLOW (42" ~ 63" TANKS) QUICK CONNECTION SLOT: 0.2mm



**CHART 4 – COMPLETE ASSEMBLY PART NUMBERS (0.2MM SLOT)**

ASSEMBLY PART NUMBER	TANK DIAMETER (INCHES)	Φ53 LATERAL PART NUMBER	ADAPTER PART NUMBER
11266-03	42"	10938	11069-E
11266-04	42"	10938	11070-M
11266-05	48"	10939	11069-E
11266-06	48"	10939	11070-M
11266-07	63"	10940	11069-E
11266-08	63"	10940	11070-M

RECOMMEND 6" FLANGE CLOSURE KITS 10584, 10585, 10916, OR 10917 ON 42"-48"-63" TANKS.





## 6" Flange Reducer Adapters Kits

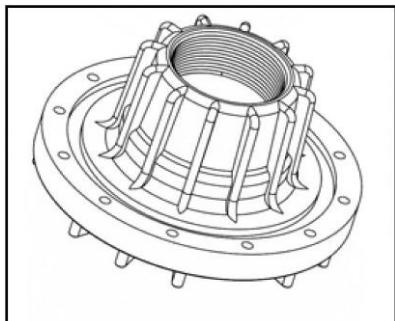

DESCRIPTION	PART NUMBER
6" FLG×3"NPT×3"NPT(10222-1) c/w o-ring seal (P/N 10228) and English bolt kit (P/N 20151)	10322
6" FLG×3"BSPP×3"BSPP(10222-2) c/w o-ring seal (P/N 10228) and English bolt kit (P/N 20151)	10323
6" FLG×3"NPT×3"BSPP(10222-3) c/w o-ring seal (P/N 10228) and English bolt kit (P/N 20151)	11299
6"FLG×4"UN×3"NPT(10223-1) c/w o-ring seals (P/N 10228),(P/N 10177) and English bolt kit (P/N 20151)	10324
6"FLG×4"UN×3"BSPP(10223-2) c/w o-ring seals (P/N 10228),(P/N 10177) and English bolt kit (P/N 20151)	10325
6" FLG×3"NPT×3"NPT(10222-1) c/w o-ring seal (P/N 10228) and Metric bolt kit (P/N 20150)	10336
6" FLG×3"BSPP×3"BSPP(10222-2) c/w o-ring seal (P/N 10228) and Metric bolt kit (P/N 20150)	10337
6" FLG×3"NPT×3"BSPP(10222-3) c/w o-ring seal (P/N 10228) and Metric bolt kit (P/N 20150)	11298
6"FLG×4"UN×3"NPT(10223-1) c/w o-ring seals (P/N 10228),(P/N 10177) and Metric bolt kit (P/N 20150)	10338
6"FLG×4"UN×3"BSPP(10223-2) c/w o-ring seals (P/N 10228),(P/N 10177) and Metric bolt kit (P/N 20150)	10339



## 6" Flange Reducer Closure Kits

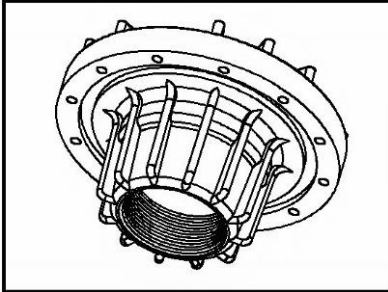

DESCRIPTION	PART NUMBER
6" FLG×4"UN×3"NPT(10340) c/w o-ring seal (P/N 10228) and English bolt kit (P/N 20151)	10584
6" FLG×4"UN×3"NPT(10340) c/w o-ring seal (P/N 10228) and Metric bolt kit (P/N 20150)	10585
6" FLG×4"UN×3"BSPP(10915) c/w o-ring seal (P/N 10228) and English bolt kit (P/N 20151)	10916
6" FLG×4"UN×3"BSPP(10915) c/w o-ring seal (P/N 10228) and Metric bolt kit (P/N 20150)	10917

## Other Accessories

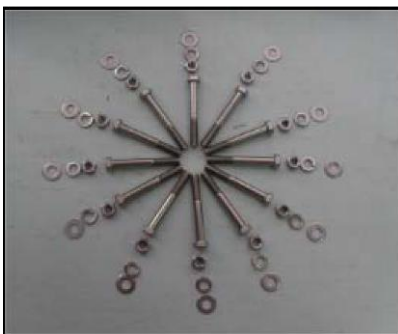

DESCRIPTION	PART NUMBER
6" FLG English bolt kit,SS304 c/w 12 sets 5/16"-18 UNC*2-3/4" screws, nuts and washers	20151
6" FLG Metric bolt kit,SS304 c/w 12 sets GB5782-86-M8*70 mm screws, nuts and washers	20150
6" FLG adapter O-ring seal,180.4mm×φ9.8mm	10228
4" adapter O-ring face seal,107mm×φ4mm	10229
4" adapter O-ring chamfer seal,92mm×φ5.3mm	10177

